

エスロン[®]クリーンパイプシステム ESLON[®] CLEAN PIPE SYSTEM

超純水用パイプ・継手・バルブ

ESLON CLEAN PIPES, FITTINGS & VALVES
for ULTRAPURE PROCESS APPLICATIONS

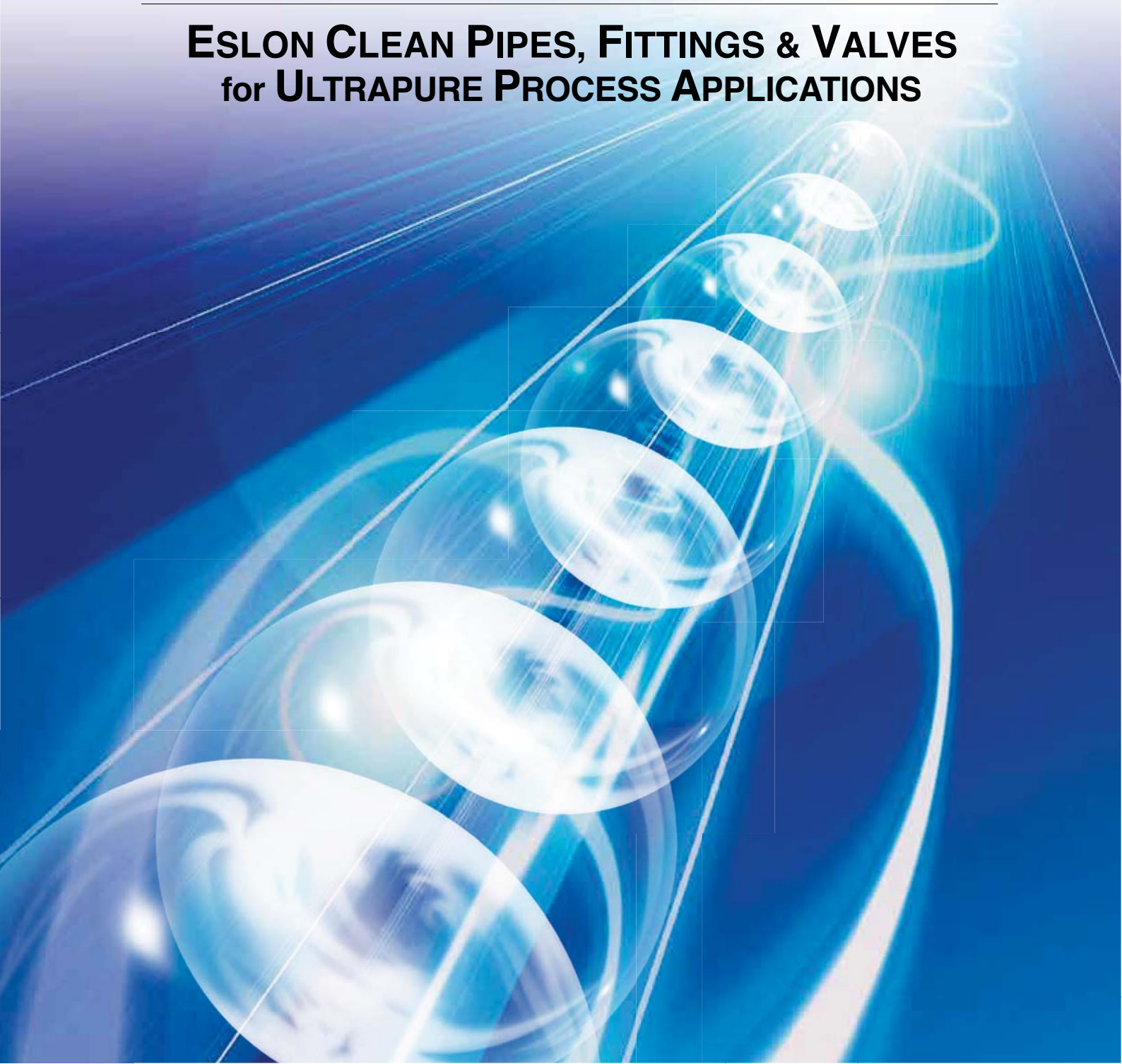

高度なクリーンが要求される 流れを確かに支える エスロン[®]クリーンパイプシステム

Absolutely suitable for a requirement of
High Purity System
Eslon[®] Clean Pipe System

日本の半導体産業が大躍進を遂げた1980年代には、VLSIの微細化技術が著しく発展し、その製造プロセスの洗浄用水として不純物が極めて少ない超純水が一般的に使用されるようになりました。

その超純水を輸送する配管材に対して、重金属やTOCの溶出が極度に少なく、しかも生菌の繁殖を防ぐために内面平滑度の高い素材が求められました。

これらのニーズに応じて、当社は1984年に世界に先駆けてエスロクリーンパイプを開発しました。

その後、熱殺菌用として耐熱性を付与したHTエスロクリーンパイプを開発したのに続き、システムの信頼を向上させるため優れた耐衝撃性を付与したエスロンスーパークリーンパイプを開発してまいりました。

現在では、積水化学のクリーン管材は、超微細化が進む半導体産業のみならずFPD産業など超純水が必要とされる先端産業において、豊富な実績に支えられ広範に使用されています。

この超純水分野において、プラスチック管材のトップメーカーである当社は、さまざまなご要望に応じて、クリーンなパイプ・継手・バルブをフルラインで品揃えしております。

Since Japanese Semiconductor industry has made remarkable progress around 1980, the micro technology for VLSI requires ultra pure water, which has almost no contamination to rinse up the semiconductor manufacturing process, has become more in use.

In order to convey the ultra pure water, the piping and accessories are required to not cause any contamination such as heavy metal and TOC. Additionally, internal surface needs to be highly smooth to prevent any bacteria.

Sekisui Chemical is the world-wide pioneer to have developed and launched our product EsloClean Pipe to answer this requirement in 1984. Ever since then, "HT EsloClean Pipe", that has heat resistance ability for sterilization, and also "Eslon Super Clean Pipe", that has additional high impact resistance, have been developed.

Now, Sekisui Eslon Clean Pipes are widely in use for applications of not only semiconductor industry, but also other high technology industry, such as FPD industry, that requires ultra pure water.

As a market leader of plastic pipe product manufacturers, we have a great variety of pipes, fittings, and valves for all kinds of your high purity applications.

CONTENTS

クリーンパイプ Clean Pipe

P3~16



エスロンスーパークリーンパイプの特長 ADVANTAGE OF ESLON SUPER CLEAN PIPE	P3
パイプ PIPE	P4
ソケット COUPLING	P4~5
エルボ ELBOW	P6~7
チーズ TEE	P7~8
キャップ CAP	P8
水栓継手 FAUCET SOCKET	P9
SUSインサート継手 SUS INSERT FAUCET SOCKET	P9~10
特殊継手エスロンユニフィット ESLON "UNIFIT" COMPACT FITTINGS	P11~12
フランジ FLANGE	P13
ユニオン継手 TRUE UNION	P14
エスロンサドルバンド ESLON SADDLE BAND	P14
エスロンクリーンヘッダー ESLON CLEAN HEADER	P15
エスロンパッキン ESLON GASKET	P16

PVDF-UHPパイプ PVDF-UHP Pipe

P17~21



エスロンPVDF-UHPパイプの特長 ADVANTAGE OF ESLON PVDF-UHP PIPE	P17
パイプ PIPE	P18
エルボ ELBOW	P18
チーズ TEE	P19
キャップ CAP	P19
ソケット COUPLING	P20
アダプター ADAPTOR	P20~21
フランジ FLANGE	P21
ユニオン TRUE UNION	P21

クリーンバルブ Clean Valves

P22~P32



ダイヤフラムバルブ DIAPHRAGM VALVE	P22
分岐ダイヤフラムバルブ DEAD SPACE FREE TEE-TYPE DIAPHRAGM VALVE	P23
ボールバルブ BALL VALVE	P24
ミニボールバルブ MINI BALL VALVE	P25
YPボールバルブ YP BALL VALVE	P26
三方型ボールバルブ 3-WAY BALL VALVE	P27
ストレーナ STRAINER	P27
バタフライバルブ BUTTERFLY VALVE	P28
チャッキバルブ CHECK VALVE	P29
リリーフバルブ RELIEF VALVE	P31
定圧弁 PRESSURE REGULATION VALVE	P31
自動式バルブ AUTOMATIC VALVES	P32

技術データ Technical Data

P33~34

基本物性 BASIC PROPERTIES	P33
溶出性能 ELUTION PERFORMANCE	P33
エスロンバルブの流量特性 FLOW CHARACTERISTICS OF ESLON VALVES	P34

施工 Installation

P35~38

取扱い、保管 HANDLING AND STORAGE	P35
接着接合 SOLVENT CEMENT JOINING	P35
融着接合 SOCKET FUSION JOINING	P37
重要な注意事項 IMPORTANT CAUTION	P38

エスロン® クリーンパイプシステム Eslon CLEAN PIPE SYSTEM

エスロン® クリーンパイプは、溶出特性に優れた経済的な超純水用クリーン管材です。

Eslon Clean Pipes & Fittings are Excellent in Super High Purity, Chemical Resistance and Lower Construction Cost.



用途に応じて2種類のクリーンパイプを用意しています。Two kinds of clean pipes are prepared according to the applications as follows.

名称 Product Name	材質 Material	サイズ Size	使用温度 Usable Temp.	最高許容圧力 Max. Working Pressure ※P.16参照	接続方式 Joint	用途 Joining Method
エスロンスーパークリーンパイプ Eslon Super Clean Pipe	耐衝撃性硬質塩化ビニル HI-PVC※1	13~300A	0~+60℃	1.0MPa	TS接続 TS Socket	超純水配管 Ultrapure Process
HTエスロクリーンパイプ HT EslonClean Pipe	耐熱性硬質塩化ビニル HT (C-PVC) ※2	16~150A	0~+90℃	1.0MPa	ソケット融着 Socket Fusion	超純水&熱滅菌 Ultrapure Process Heat Sterilization

※1: JIS K6741, JIS K6742 の認定品ではありません
 ※2: JIS K6776 の認定品ではありません

特長 Advantage

■独自のPVC配合や成形技術により極めて少ないTOCや金属溶出を達成

Extremely little elution of heavy metal or TOC, based on many proprietary technologies of PVC formulation and extrusion.

■TOCと金属の溶出性能

Elution of TOC and Heavy Metals

単位Unit: $\mu\text{g}/\text{m}^2 \cdot \text{day}$

名称 Product Name	温度 Temperature	TOC	Ca	Mg	Na
エスロンスーパークリーンパイプ Eslon Super Clean Pipe	常温 Room Temp	5.0	0.06	0.005	0.003
HTエスロクリーンパイプ HT EslonClean Pipe	常温 Room Temp	11	0.28	0.05	<0.003
	80℃	613	0.16	0.03	<0.003

※半導体基盤技術研究会提唱の短管封水試験法による8~30日間の測定値
 Data for 8-30 days by the UCT/Japan test method.

■管内面の表面粗さは平滑で、生菌の増殖やコンタミを防止します

The pipe inside surface is finished very smooth like mirror, then it prevents proliferation and contamination.

パイプサイズ Pipe Size	13~150	200~300	
表面粗さ Surface Roughness	Pt	0.25 μm	0.30 μm

※実測値であり、保証値ではありません。
 This data is intended to serve as reference.

■電子顕微鏡写真 Microscope photographs of the inside surface of EslonClean pipe

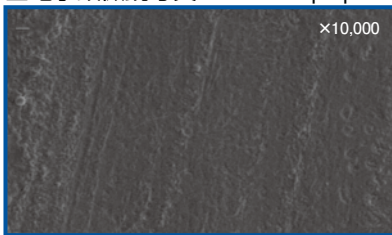

エスロンスーパークリーンパイプ
Eslon Super Clean Pipe

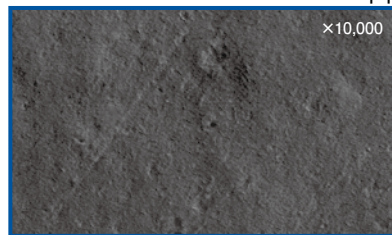

HTエスロクリーンパイプ
HT EslonClean Pipe

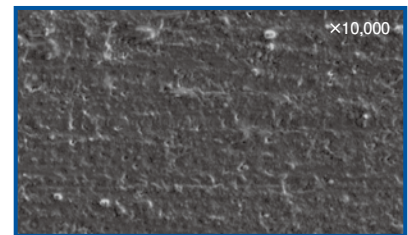

通常の塩ビ管
Ordinary U-PVC Pipe

■接着剤を使用しない融着接合を行えば、さらに高い溶出性能が得られます。

It reaches extremely less elution performance by the socket heat fusion joining, if it doesn't use the solvent cement in the jointing.

■線膨張係数がPPやPVDFの1/2なので、熱伸縮処理が容易です。

Since the linear expansion coefficient of Eslon Clean Pipe is 1/2 of PP or PVDF, counter measure for the heat expansion and contraction is easy.

パイプ PIPE

パイプ Pipe

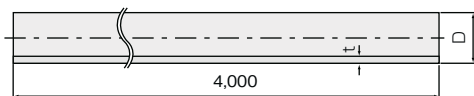

HI-PVC

単位Unit: mm

呼び径 A	Size B	D	t	重量 Weight (kg/m)
13	3/8	18.0	2.5	0.170
16	1/2	22.0	3.0	0.251
20	3/4	26.0	3.0	0.303
25	1	32.0	3.5	0.439
30	1-1/4	38.0	3.5	0.531
40	1-1/2	48.0	4.0	0.774
50	2	60.0	4.5	1.098
65	2-1/2	76.0	4.5	1.415
75	3	89.0	5.9	2.156
100	4	114.0	7.1	3.338
125	5	140.0	7.5	4.370
150	6	165.0	9.6	6.561
200	8	216.0	11.0	9.918
250	10	267.0	13.6	15.157
300	12	318.0	16.2	21.504

HT(C-PVC)

単位Unit: mm

呼び径 A	Size B	D	t	重量 Weight (kg/m)
16	1/2	22.0	3.0	0.265
20	3/4	26.0	3.0	0.321
25	1	32.0	3.5	0.464
30	1-1/4	38.0	3.5	0.561
40	1-1/2	48.0	4.0	0.818
50	2	60.0	4.5	1.161
65	2-1/2	76.0	5.0	1.628
75	3	89.0	5.8	2.213
100	4	114.0	7.0	3.435
125	5	140.0	8.2	4.957
150	6	165.0	9.7	6.910

寸法は JIS K 6776 に準拠
Dimensions are in accordance with JIS K 6776

寸法は JIS K 6741 に準拠
Dimensions are in accordance with JIS K 6741

継手 FITTINGS

継手受口共通寸法 Socket Dimension

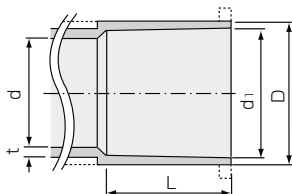

●65A以上は「J」の形状になります。
The shape of the socket end in 65A and above is 「J」 as illustrated.

HI-PVC

単位Unit: mm

呼び径 A	Size B	D	t	d ₁	L	d
13	3/8	24	3.0	18.40	26	13
16	1/2	29	3.5	22.40	30	16
20	3/4	33	3.5	26.45	35	20
25	1	40	4.0	32.55	40	25
30	1-1/4	46	4.0	38.60	44	31
40	1-1/2	57	4.5	48.70	55	40
50	2	70	5.0	60.80	63	51
65	2-1/2	87	6.6	76.60	61	67
75	3	102	8.0	89.60	64	77
100	4	130	10.0	114.70	84	100
125	5	157	11.0	140.85	104	125
150	6	186	13.0	166.00	132	146
※200	8	243	13.0	217.4	145	196
※250	10	300	14.5	268.6	175	242
※300	12	356	16.0	319.8	185	288

注1: 受口寸法及び全長は JIS K 6743 に準拠
Note1: Dimensions are in accordance with JIS K 6743
※200~300AのD, t, d₁, Lは品種により多少異なりますので、承認図で確認をお願いします。
Since there are some differences among types of fittings in their D, t, d₁ and L for 200~300A, confirm them in the approval drawing.

HT(C-PVC)

単位Unit: mm

呼び径 A	Size B	D	t	d ₁	L	d
16	1/2	29	3.5	22.35	27	17
20	3/4	34	4.0	26.35	33	21
25	1	41	4.0	32.50	38	26
30	1-1/4	46	4.5	38.50	42	34
40	1-1/2	56	4.5	48.50	47	40
50	2	69	5.0	60.50	52	50
65	2-1/2	91	6.1	76.70	70	68
75	3	106	7.0	89.70	75	78
100	4	134	9.4	114.85	94	102
125	5	166	10.4	140.80	104	125
150	6	189	12.2	166.00	132	146

注1: 受口寸法及び全長は JIS K 6777 に準拠
Note1: Dimensions are in accordance with JIS K 6777

■最高許容圧力 (MPa)

呼び径 Size	HI-PVC	HT
15-150A	1.0	1.0
200-250A	0.75(1.0)	
300A	0.6(1.0)	

※1. ()内はFRP補強品の数値です。
Note1: () is a pressure for Fiber Reinforced fitting.
※2. ブッシュタイプ、ユニフィットの200~300Aの耐圧は0.6MPaです。
Note2: Max. Working Pressure for 200~300A for Bush type, Unifit is 0.6MPa.
※3. 止水フランジは、P.13をご参照ください。
Note3: Please refer to P.13 about the pressure of Blind Flange.

ソケット COUPLING

同径ソケット Coupling

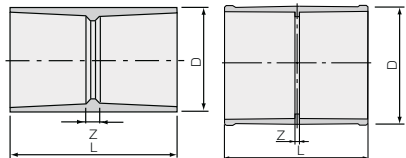

13~50

65~150

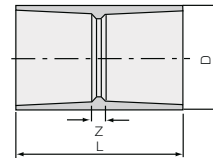

15~50

HI-PVC

単位Unit: mm

呼び径 Size	D	L	Z	重量 Weight (kg)
13	24	57	5	0.018
16	29	67	7	0.028
20	33	77	7	0.040
25	40	87	7	0.061
30	46	95	7	0.078
40	57	117	7	0.142
50	70	133	7	0.210
65	87	145	23	0.366
75	102	155	27	0.515
100	130	200	32	1.077
125	157	240	32	1.715
150	186	300	36	2.846
200	243	300	10	3.450
250	300	384	34	6.660
300	356	408	38	8.860

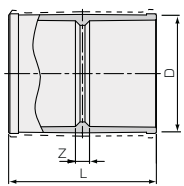

破線はFRP補強品の1.0MPa仕様です。
Dashed shape for Fiber Reinforced :1.0MPa fitting.

HT(C-PVC)

単位Unit: mm

呼び径 Size	D	L	Z	重量 Weight (kg)
16	31	56	5	0.033
20	36	76	5	0.058
25	42	86	5	0.077
30	48	86	6	0.083
40	58	97	6	0.142
50	70	107	6	0.195
65	87	145	6	0.298
75	102	155	9	0.493
100	130	201	12	1.102
125	157	239.5	28.5	1.840
150	186	295.5	28.5	3.068

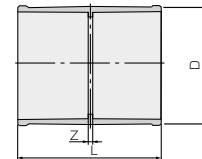

65~150

継手 FITTINGS

異径ソケット Reducing Coupling



※プッシュタイプ

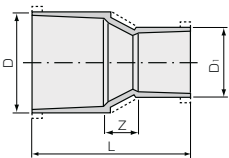

13~150

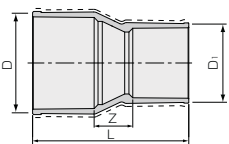

200~300

破線はFRP補強品の1.0MPa仕様です。
Dashed shape for Fiber Reinforced 1.0MPa fitting.

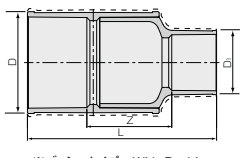

※プッシュタイプ With Bushing

HI-PVC

呼び径 Size	D	D ₁	L	Z	重量 Weight (kg)
16×13	29	24	61	5	0.024
20×13	33	24	68	7	0.031
20×16	33	29	71	6	0.036
25×13	40	24	86	20	0.046
25×16	40	29	85	15	0.048
25×20	40	33	84	9	0.053
30×13	46	24	95	25	0.058
30×20	46	33	93	14	0.060
30×25	46	40	93	9	0.071
40×20	57	33	113	23	0.095
40×25	57	40	114	19	0.110
40×30	57	46	114	15	0.118
50×20	70	33	116	18	0.153
50×25	70	40	140	37	0.180
50×30	70	46	136	29	0.167
50×40	70	57	136	18	0.185
65×50	87	70	149	25	0.336
75×50	102	70	165	38	0.450
75×65	102	87	159	38	0.487
100×75	130	102	190	42	0.890
125×100	157	130	229	41	1.531
150×100	186	130	295	79	2.348
150×125	186	157	272	36	2.369
200×150	243	189	368	91	3.830
※250×150	300	189	557	250	11.770
250×200	300	243	400	80	5.900
※300×150	356	189	605	288	13.970
※300×200	356	243	601	271	15.920
300×250	356	300	435	75	8.860

※プッシュタイプ With Bushing
※最高許容圧力は0.6MPaです。
Max.Working Pressure:0.6MPa

A-I型 (A-IType)

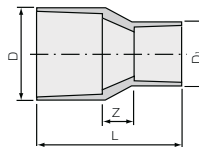

16~50

HT(C-PVC)

呼び径 Size	D	D ₁	L	Z	重量 Weight (kg)
20×16	36	29	66	6	0.049
25×16	42	29	76	11	0.039
25×20	42	34	80.5	9.5	0.072
30×20	48	34	85	10	0.041
30×25	48	41	90	10	0.880
40×20	58	34	98	18	0.111
40×25	58	41	100	15	0.116
40×30	58	46	97	8	0.130
50×25	70	41	110	20	0.155
50×30	70	46	110	16	0.154
50×40	70	56	110	11	0.105

A-II型 (A-IIType)

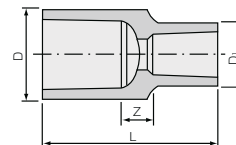

50~125

HT(C-PVC)

呼び径 Size	D	D ₁	L	Z	重量 Weight (kg)
50×16	76	31	103	10	0.231
50×20	76	33	109	11	0.243
50×25	76	40	113	10	0.250
50×30	76	48	113	10	0.265
50×40	76	57	128	20	0.287
65×20	89	33	113	17	0.265
65×25	89	40	119	18	0.275
65×30	89	48	119	18	0.285
65×40	89	57	134	28	0.310
65×50	89	70	142	31	0.330
75×20	114	36	132	25	0.672
75×25	114	40	138	26	0.680
75×30	114	48	138	26	0.690
75×40	114	57	142	25	0.700
75×50	114	70	148	26	0.710
75×65	114	87	161	28	0.755
100×20	140	36	144	17	0.104
100×25	140	42	150	18	0.105
100×50	140	70	160	18	0.109
100×65	140	87	170	17	1.111
100×75	140	101	184	20	1.300
125×20	165	36	175	36	1.620
125×25	165	42	180	36	1.630
125×75	165	101	219	43	1.680
125×100	165	130	233	37	1.900

B型 (B Type)

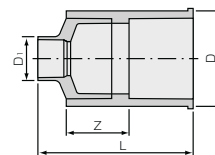

65~150

HT(C-PVC)

呼び径 Size	D	D ₁	L	Z	重量 Weight (kg)
65×16	87	31	154	55	0.529
100×30	130	42	246	114	1.792
100×40	130	48	251	114	1.802
125×50	157	70	288	126	2.949
125×65	157	88	293	120	2.951
150×20	186	36	338	169	4.688
150×25	186	42	343	169	4.698
150×75	186	102	381	168	4.748
150×100	186	131	396	168	4.968
150×125	186	158	407	169	5.068

継手 FITTINGS

エルボ ELBOW

90°エルボ

90°Elbow

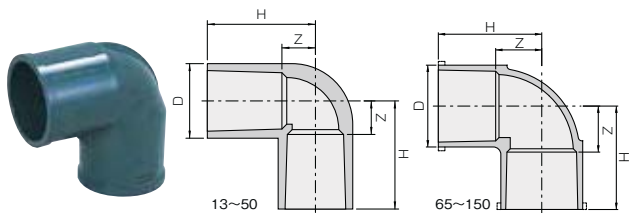

HI-PVC

呼び径 Size	D	H	Z	重量 Weight (kg)
13	24	36	10	0.022
16	29	43	13	0.036
20	33	52	17	0.050
25	40	60	20	0.076
30	46	67	22	0.105
40	58	82	29	0.201
50	70	99	36	0.309
65	87	114	48	0.536
75	102	125	59	0.803
100	130	156	70	1.653
125	160	186	82	2.760
150	189	229	98	4.584
200	243	262	117	6.600
250	300	318	143	10.800
300	356	355	170	15.500

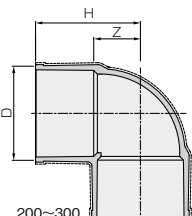

破線はFRP補強品の1.0MPa仕様です。
Dashed shape for Fiber Reinforced 1.0MPa fitting.

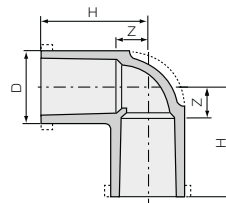

HT(C-PVC)

呼び径 Size	D	H	Z	重量 Weight (kg)
16	31	38.5	13	0.041
20	36	50	15	0.069
25	42	58.5	18	0.094
30	48	63	22.5	0.122
40	58	73.5	28	0.183
50	70	85.5	35	0.272
65	91	114	43.5	0.551
75	106	123.5	45.5	0.856
100	134	156	60	1.740
125	166	189	83	2.970
150	189	230	96	5.047

90°ベンド

90°Bend

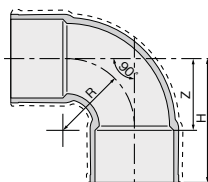

破線はFRP補強品の1.0MPa仕様です。
Dashed shape for Fiber Reinforced 1.0MPa fitting.

HI-PVC

呼び径 Size	H	Z	R	重量 Weight (kg)
200	341	196	196	7.370
250	428	253	242	13.970
300	441	256	242	19.690

45°エルボ

45°Elbow

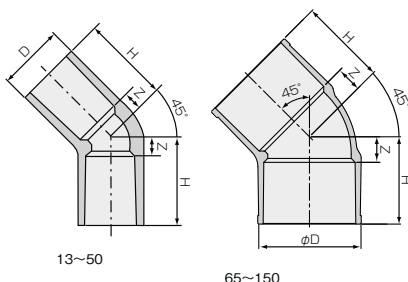

HI-PVC

呼び径 Size	D	H	Z	重量 Weight (kg)
13	24	36	10	0.018
20	33	44	9	0.039
25	40	51	11	0.065
30	46	56	12	0.078
40	57	69	14	0.133
50	70	81	18	0.245
65	87	94	33	0.460
75	102	98	34	0.660
100	130	123	39	1.262
125	160	149	44	1.700
150	190	184	51	3.120
200	243	205	60	5.600
250	300	254	79	8.760
300	356	280	95	13.200

破線はFRP補強品の1.0MPa仕様です。
Dashed shape for Fiber Reinforced 1.0MPa fitting.

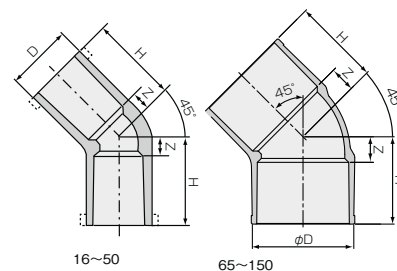

HT(C-PVC)

呼び径 Size	D	H	Z	重量 Weight (kg)
16	29	33	8	0.041
20	34	44	9	0.067
25	41	50	10	0.090
30	46	53	13	0.110
40	56	61	16	0.155
50	69	80	30	0.296
65	91	94	24	0.495
75	106	98	26	0.740
100	134	123	31	1.330
125	166	149	44	1.800
150	189	184	51	3.300

継手 FITTINGS

90°異径エルボ 90° Reducing Elbow

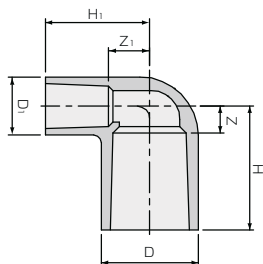

HI-PVC

単位Unit: mm

呼び径 Size	D	D ₁	H	H ₁	Z	Z ₁	重量 Weight (kg)
20×13	33	24	46	40	11	14	0.035
25×13	40	24	51	43	11	17	0.048
25×20	40	33	55	53	15	18	0.064

チーズ TEE

同径チーズ Equal Tee

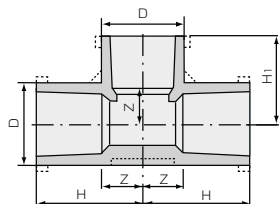

13~50

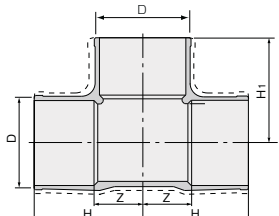

65~300

破線はFRP補強品の1.0MPa仕様です。
Dashed shape for Fiber Reinforced 1.0MPa fitting.

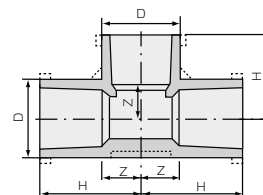

HT(C-PVC)

単位Unit: mm

呼び径 Size	D	H	Z	重量 Weight (kg)
16	31	38.5	13	0.055
20	36	50.5	15	0.087
25	42	58.5	18	0.136
30	48	63	23	0.154
40	58	73.5	28	0.300
50	70	85.5	35	0.382
65	87	113.5	43	0.822
75	102	123.5	51	1.112
100	130	155.5	63	2.348
125	157	188	83	4.200
150	186	230	98	6.280

HI-PVC

単位Unit: mm

呼び径 Size	D	H	H ₁	Z	重量 Weight (kg)
13	24	37	37	8	0.030
16	29	43	43	13	0.050
20	33	52	52	15	0.070
25	40	60	60	18	0.119
30	46	65	65	21	0.145
40	57	82	82	27	0.276
50	70	98	98	33	0.443
65	87	114	114	50	0.769
75	102	123	123	58	1.158
100	130	152	152	68	2.254
125	160	189	189	84	3.980
150	187	233	233	100	6.365
200	243	267	267	122	7.940
250	300	355	355	180	18.250
300	356	410	410	225	29.530

継手 FITTINGS

異径チース

Reducing Tee

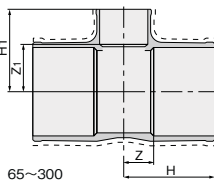

破線はFRP補強品の1.0MPa仕様です。
Dashed shape for Fiber Reinforced 1.0MPa fitting.

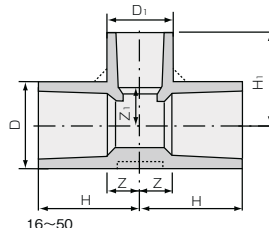
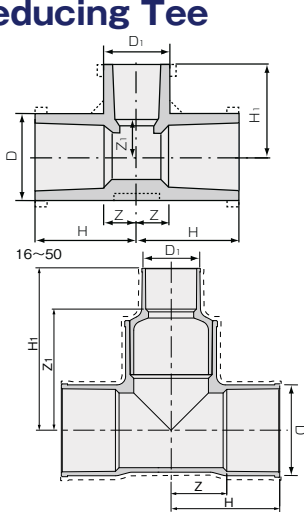

16~50

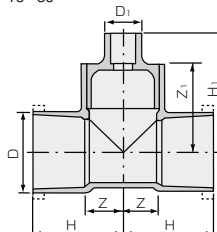

65~150

HI-PVC

呼び径 Size	D	D ₁	H	H ₁	Z	Z ₁	重量 Weight (kg)
16×13	29	24	42	42	10	14	0.045
20×13	33	24	47	41	12	16	0.059
20×16	33	29	48	45	13	15	0.059
25×13	40	24	53	46	12	19	0.078
25×16	40	29	53	48	13	18	0.086
25×20	40	33	57	54	15	18	0.091
30×13	46	24	56	48	11	22	0.099
30×16	46	29	59	53	13	21	0.106
30×20	46	33	60	58	15	21	0.111
30×25	46	40	64	63	19	23	0.132
40×13	57	24	68	53	11	26	0.152
40×16	57	29	70	57	13	25	0.173
40×20	58	33	72	64	17	28	0.182
40×25	58	40	74	68	18	27	0.208
40×30	57	46	77	72	21	27	0.200
50×13	70	24	76	58	11	30	0.227
50×16	70	29	76	63	13	31	0.258
50×20	70	33	78	70	15	35	0.280
50×25	70	40	81	73	18	33	0.283
50×30	70	46	85	79	21	33	0.297
50×40	70	57	91	89	28	34	0.345
65×50	87	70	102	107	40	42	0.616
75×25	103	42	93	88	29	48	0.670
75×40	102	57	100	102	36	47	0.816
75×50	102	70	105	110	41	47	0.907
75×65	102	87	115	119	49	56	1.012
100×50	130	72	125	122	41	59	1.486
100×75	130	102	140	132	54	66	1.818
125×100	160	130	176	167	72	83	3.317
150×75	186	102	195	158	63	94	4.246
150×100	186	134	207	181	76	98	4.954
150×125	186	157	217	201	85	97	5.125
200×75	243	102	201	180	56	116	5.415
200×100	243	134	218	200	73	116	5.920
200×150	243	189	245	257	100	125	8.150
250×75	300	102	246	210	71	146	8.370
250×100	300	130	267	225	92	141	9.345
*250×150	300	189	355	524	180	392	22.360
250×200	300	243	335	335	160	190	15.620
300×75	356	102	260	236	75	172	12.390
300×100	356	130	266	257	81	173	12.880
*300×150	356	189	375	561	190	429	29.840
*300×200	356	243	410	599	225	454	36.590
300×250	356	300	375	392	190	217	24.730

ブッシュタイプ
With Bushing

HT(C-PVC)

呼び径 Size	D	D ₁	H	H ₁	Z	Z ₁	重量 Weight (kg)
20×16	36	31	48.5	40	13	14.5	0.085
25×16	42	31	53.5	43.5	13.5	18.5	0.106
25×20	42	36	55.5	51	15.5	16	0.122
30×16	48	31	54	47.5	13.5	22	0.124
30×20	48	36	56	57.5	15.5	22	0.140
30×25	48	42	58.5	62.5	18	22	0.156
40×16	58	31	61.5	53	16	27.5	0.179
40×20	58	36	63.5	63.5	18	28	0.193
40×25	58	42	66	68	20.5	27.5	0.205
40×30	58	48	70	68	24.5	27.5	0.220
50×16	70	31	68.5	60	18	34.5	0.250
50×20	70	36	70.5	70	20	34.5	0.275
50×25	70	42	73	75	22.5	34.5	0.304
50×30	70	48	77	75	26.5	34.5	0.303
50×40	70	58	80	80	29.5	34.5	0.363
65×16	87	31	113.5	122.5	43	91.5	1.053
65×20	87	36	113.5	128	43	92.5	1.065
65×25	87	42	113.5	133	43	93	1.072
65×30	87	48	113.5	132	43	91.5	1.087
65×40	87	58	113.5	147	43	101.5	1.109
65×50	87	70	113.5	156	43	105.5	1.132
75×20	102	36	123.5	140.5	50.5	99	1.337
75×25	102	42	123.5	146.5	50.5	106	1.387
75×30	102	48	123.5	148.5	50.5	108	1.397
75×40	102	58	123.5	161.5	50.5	116.5	1.422
75×50	102	70	123.5	169	50.5	118.5	1.422
75×65	102	87	123.5	168	50.5	106.5	1.477
100×20	130	36	155.5	179.5	63	154.5	3.030
100×25	130	42	155.5	185.5	63	145	3.028
100×30	130	48	155.5	185	63	144.5	3.038
100×40	130	58	155.5	191	63	145.5	3.048
100×50	130	70	155.5	195.5	63	145	3.058
100×65	130	87	155.5	209	63	147	3.103
100×75	130	102	155.5	225	63	151.5	3.168
125×20	157	36	188	209	83	173.5	5.240
125×25	157	42	188	214.5	83	174	5.250
125×50	157	70	188	224	83	173.5	5.290
125×65	157	87	188	235	83	173.5	5.310
125×75	157	102	188	247	83	173	5.500
125×100	157	130	188	267	83	174.5	5.600
150×20	186	36	230	247	98	211.5	7.900
150×25	186	42	230	251.5	98	211	7.910
150×75	186	102	230	290	98	210.5	7.960
150×100	186	130	230	305	98	211	8.180
150×125	186	157	230	315.5	98	211	8.280

*ブッシュタイプ
With Bushing
*最高許容圧力は0.6MPaです。
Max. Working Pressure: 0.6MPa

キャップ CAP

キャップ

Cap

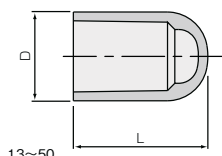

13~50

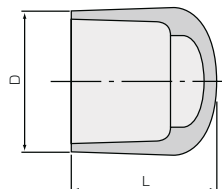

75, 100

HI-PVC

呼び径 Size	D	L	重量 Weight (kg)
13	24	36.5	0.011
16	29	43.0	0.017
20	33	50.0	0.023
25	40	58.5	0.035
30	46	65.5	0.050
40	57	82.0	0.102
50	70	96.5	0.125
75	102	105.0	0.442
100	130	138.0	0.775

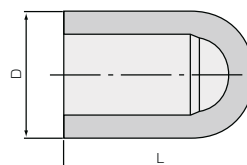

HT(C-PVC)

呼び径 Size	D	L	重量 Weight (kg)
16	31	39.5	0.021
20	36	52	0.037
25	42	60	0.055
30	48	63.5	0.064
40	58	73.5	0.096
50	70	85	0.138

継手 FITTINGS

水栓継手 FAUCET FITTINGS

注:ねじ部はJIS B 0203(管用テーパードネジ)の平行めねじまたはテーパードネジとなります。
Note:The thread dimensions are in accordance with JIS B 0203.

水栓ソケット Faucet Socket

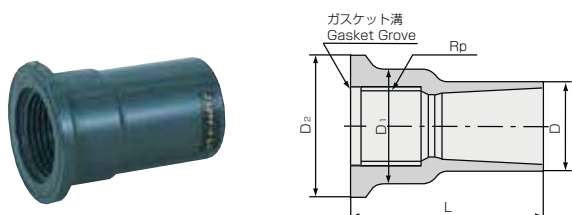

HI-PVC

呼び径 Size	D	D ₁	D ₂	L	重量 Weight (kg)
13 × Rp1/2	24	28	34	47	0.020
16 × Rp1/2	29	29	34	52	0.026
20 × Rp3/4	33	35	42	59	0.036
25 × Rp1	40	43	52	68	0.060

単位Unit: mm

水栓エルボ Faucet Elbow

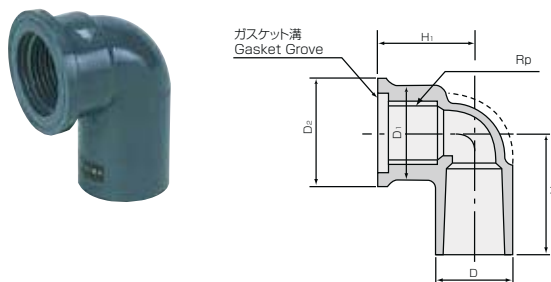

HI-PVC

呼び径 Size	D	D ₁	D ₂	H	H ₁	重量 Weight (kg)
13 × Rp1/2	24	28	34	38	29	0.025
16 × Rp1/2	29	29	34	43	32	0.034
20 × Rp3/4	33	35	42	51	36	0.050
25 × Rp1	40	43	52	59	40	0.082

単位Unit: mm

水栓チーズ Faucet Tee

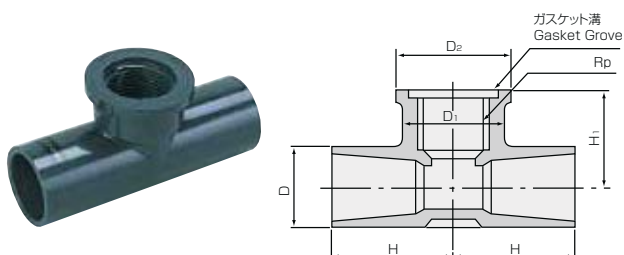

HI-PVC

呼び径 Size	D	D ₁	D ₂	H	H ₁	重量 Weight (kg)
13 × Rp1/2	24	28	34	38	29	0.036
20 × Rp1/2	33	28	34	47	34	0.070
20 × Rp3/4	33	35	42	51	36	0.115
25 × Rp1	40	43	52	59	42	0.060

単位Unit: mm

バルブソケット Male Adaptor

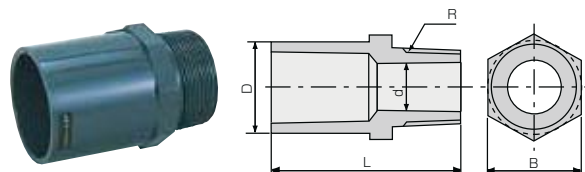

呼び径30以上は八角形になります。
In nominal diameters 30A and above, the nut parts are shaped octagonal.

HI-PVC

呼び径 Size	D	d	L	B	重量 Weight (kg)
13 × R1/2	24	13	50	24	0.016
16 × R1/2	29	13	54	29	0.023
20 × R3/4	33	18	64	33	0.032
25 × R1	40	23	71	40	0.047
30 × R1 1/4	46	31	80	46	0.066
40 × R1 1/2	57	37	92	57	0.100
50 × R2	70	48	106	70	0.168
65 × R2 1/2	87	63	119	91	0.272
75 × R3	102	74	128	108	0.402
100 × R4	130	96	157	135	0.765

単位Unit: mm

SUSインサート継手 SUS INSERTED FAUCET FITTINGS

注:ねじ部はJIS B 0203(管用テーパードネジ)の平行めねじまたはテーパードネジとなります。
Note:The thread dimensions are in accordance with JIS B 0203.

SUSインサート給水栓ソケット SUS Inserted Faucet Socket

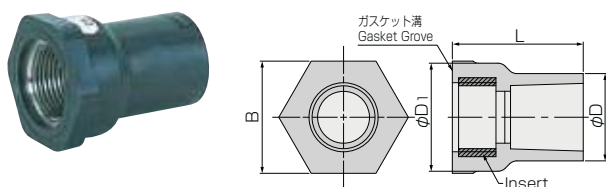

PVC

呼び径 Size	D	D ₁	B	L	重量 Weight (kg)
13 × Rp3/8	27.5	34	35	46	0.066
13 × Rp1/2	27.5	34	35	46	0.055
16 × Rp3/8	31	34	35	52	0.069
16 × Rp1/2	31	34	35	52	0.058
20 × Rp1/2	36	42	44	63	0.121
20 × Rp3/4	36	42	44	63	0.096
25 × Rp1	42	52	54	72	0.149

単位Unit: mm

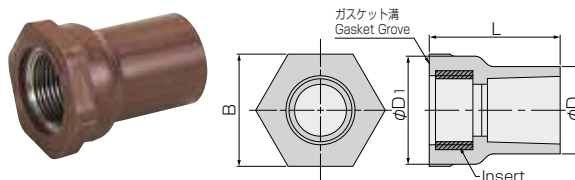

HT(C-PVC)

呼び径 Size	D	D ₁	B	L	重量 Weight (kg)
16 × Rp3/8	31	34	35	52	0.069
16 × Rp1/2	31	34	35	52	0.058
20 × Rp1/2	36	42	44	63	0.121
20 × Rp3/4	36	42	44	63	0.096
25 × Rp1	42	52	54	72	0.149

単位Unit: mm

継手 FITTINGS

SUSインサート給水栓エルボ SUS Inserted Faucet Elbow

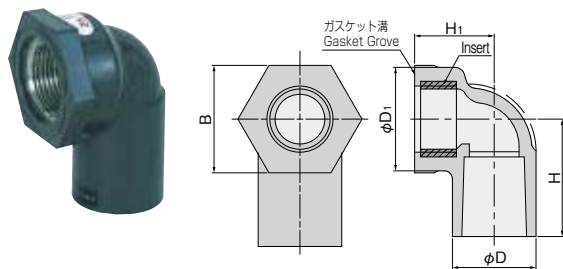

PVC

呼び径 Size	D	D ₁	B	H	H ₁	重量 Weight (kg)
13×Rp3/8	27.5	34	35	33	29	0.073
13×Rp1/2	27.5	34	35	33	29	0.062
16×Rp3/8	31	34	35	38	32	0.081
16×Rp1/2	31	34	35	38	32	0.070
20×Rp1/2	36	42	44	51	36	0.136
25×Rp1	42	52	54	64	40	0.170

単位 Unit : mm

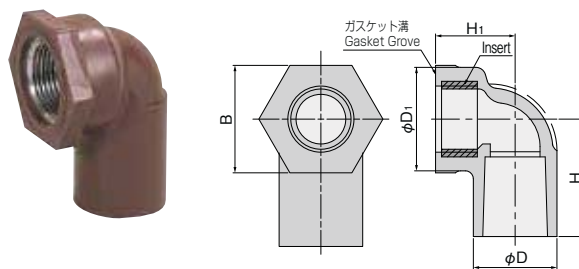

HT(C-PVC)

呼び径 Size	D	D ₁	B	H	H ₁	重量 Weight (kg)
16×Rp3/8	31	34	35	38	32	0.081
16×Rp1/2	31	34	35	38	32	0.070
20×Rp1/2	36	42	44	51	36	0.136
25×Rp1	42	52	54	64	40	0.170

単位 Unit : mm

SUSインサート給水栓チース SUS Inserted Faucet Tee

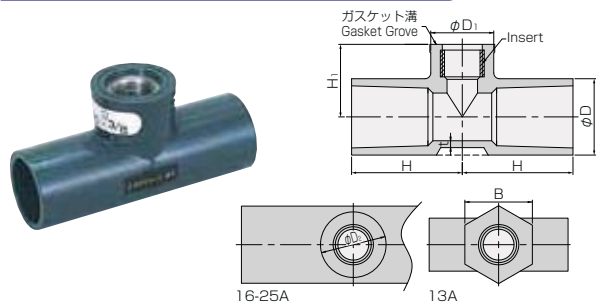

PVC

呼び径 Size	D	D ₁	D ₂	B	H	H ₁	重量 Weight (kg)
13×Rp3/8	27.5	34	—	35	34	29	0.084
13×Rp1/2	27.5	34	—	35	36	32	0.073
16×Rp3/8	29	33	34	—	43	32	0.085
16×Rp1/2	29	33	34	—	43	32	0.074
20×Rp3/8	33	33	34	—	48	34	0.102
20×Rp1/2	33	33	34	—	48	34	0.126
25×Rp3/8	40	33	34	—	53	38	0.121
25×Rp1/2	40	33	34	—	53	38	0.145

単位 Unit : mm

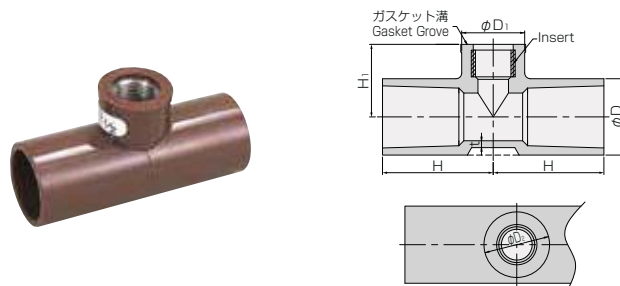

HT(C-PVC)

呼び径 Size	D	D ₁	D ₂	H	H ₁	重量 Weight (kg)
16×Rp3/8	29	33	34	43	32	0.085
16×Rp1/2	29	33	34	43	32	0.074
20×Rp3/8	33	33	34	48	34	0.102
20×Rp1/2	33	33	34	48	34	0.126
25×Rp3/8	40	33	34	53	38	0.121
25×Rp1/2	40	33	34	53	38	0.145

単位 Unit : mm

SUSインサートバルブソケット SUS Inserted Male Adaptor

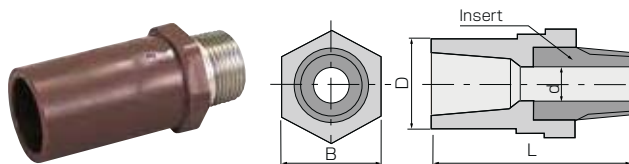

HT(C-PVC)

呼び径 Size	D	d	L	B	重量 Weight (kg)
16×R1/2	31	13	70	34	0.091
20×R3/4	36	18	85	40	0.144
25×R1	42	28	99	45	0.247
30×R1 1/4	48	31	109	62	0.486
40×R1 1/2	58	37	114	68	0.572
50×R2	70	48	132	84	0.980

単位 Unit : mm

特殊継手 エスロンユニフィット ESLON "UNIFIT" COMPACT FITTINGS

① 充実のフルラインアップ Easy Selection for Piping Design

エスロン ユニフィットの品揃えにより、エスロン継手の品揃えがますます充実しました。
今までできなかった配管設計が可能となり、設計の自由度が向上します。

ESLON Compact fitting & Header offer the easy selection for designer and installer. This will enable to make a new piping design that was impossible in the past.

② コンパクト形状 Compact Fittings & Minimized Piping Space

当社独自のブッシュ融着方式により、優れた耐圧性能・溶出性能(TOC、重金属など)を有するコンパクト継手で、省スペース配管ができます。

ESLON Compact fitting & Header are compact and piping in a narrow place can be carried out. By adopting our original fusion method with bushings, these fittings have outstanding pressure resistance and elution performances(TOC, heavy metal, etc.).

③ トータルコスト低減 Easy Installation & Low Piping Cost

継手点数や接続箇所が低減するので、施工性が大幅に改善できます。
施工を含めたトータルコストが低減されます。

ESLON Compact fitting & Header are easy to install by reducing number of fittings and jointing. These features lead to lower piping cost.

ねじ付ブッシングチース

Bushing Tee with Female Thread

T型 T-Type



PAT.No.1915097

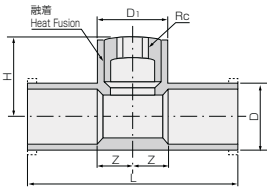

注:ねじ部は JIS B 0203(管用テーパネジ)に準じます。
Note:The thread dimensions are in accordance with JIS B 0203.

HI-PVC

呼び径 Size	L	H	D	D ₁	Z	ねじ径 Thread Size
20	100	41	33	33	15	Rc 1/4 3/8
25	116	44	40	40	18	Rc 1/4 3/8 1/2
30	130	48	46	47	21	Rc 1/4 3/8 1/2 3/4
40	164	56	57	58	27	Rc 1/4 3/8 1/2 3/4 1
50	180	62	70	58	27	Rc 1/4 3/8 1/2 3/4 1
65	202	70	87	72	40	Rc 1/4 3/8 1/2 3/4 1
75	226	91	102	88	49	Rc 1/4 3/8 1/2 3/4 1
100	280	103	130	103	56	Rc 1/4 3/8 1/2 3/4 1
125	346	125	157	131	69	Rc 1/4 3/8 1/2 3/4 1
150	390	129	186	108	63	Rc 1/4 3/8 1/2 3/4 1
※200	436	155	243	140	73	Rc 1/4 3/8 1/2 3/4 1

※最高許容圧力は0.6MPaです。
Max.Working Pressure:0.6MPa

L型 L-Type



PAT.No.1915097

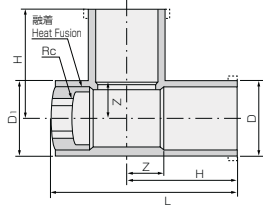

HI-PVC

呼び径 Size	L	H	D	D ₁	Z	ねじ径 Thread Size
20	91	50	33	33	15	Rc 1/4 3/8
25	102	58	40	40	18	Rc 1/4 3/8 1/2
30	113	65	46	47	21	Rc 1/4 3/8 1/2 3/4
40	138	82	57	58	27	Rc 1/4 3/8 1/2 3/4 1
50	158	96	70	71	33	Rc 1/4 3/8 1/2 3/4 1
65	194	110	87	88	49	Rc 1/4 3/8 1/2 3/4 1
75	211	120	102	101	56	Rc 1/4 3/8 1/2 3/4 1
100	262	152	130	131	68	Rc 1/4 3/8 1/2 3/4 1

TSブッシングチース

Bushing Tee with TS Socket

T型 T-Type

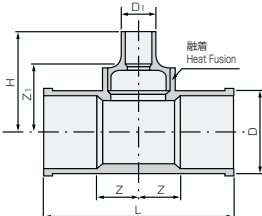

HI-PVC

呼び径 Size	L	H	D	D ₁	Z	Z ₁
65 × 16	115		31		85	
65 × 20	120		36		85	
65 × 25	125	87	42	49	85	
65 × 30	124		48		82	
65 × 40	140		58		92	
75 × 16	122		36		92	
75 × 20	127	102	36	49	92	
75 × 30	131		48		89	
100 × 16	139		36		109	
100 × 20	139		36		104	
100 × 25	145		42		105	
100 × 30	145	130	48	56	103	
100 × 40	160		58		112	
100 × 65	167		87		107	
125 × 16	161		36		131	
125 × 20	161		36		126	
125 × 25	166		42		126	
125 × 30	167	157	48	69	125	
125 × 40	172		58		124	
125 × 50	177		70		124	
125 × 65	190		87		130	
125 × 75	198		102		134	
150 × 16	165		36		135	
150 × 20	165		36		130	
150 × 25	171		42		131	
150 × 30	171	186	48	63	129	
150 × 40	186		58		138	
150 × 50	194		70		141	
150 × 65	193		87		133	
※200 × 16	195		36		165	
※200 × 20	195		36		160	
※200 × 25	200		42		160	
※200 × 30	201		48		161	
※200 × 40	206	243	58	72.65	161	
※200 × 50	211		70		161	
※200 × 65	224		87		163	
※200 × 75	232		102		160	

※最高許容圧力は0.6MPaです。
Max.Working Pressure:0.6MPa

L型 L-Type

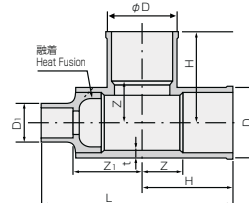

HI-PVC

呼び径 Size	L	H	D	D ₁	Z	Z ₁
65 × 16	225		31		85	
65 × 20	230		36		85	
65 × 25	235	110	42	49	85	
65 × 30	234		48		82	
65 × 40	250		58		92	
75 × 16	247		36		97	
75 × 20	247		36		92	
75 × 25	253		42		93	
75 × 30	253	120	48	56	91	
75 × 40	268		58		100	
75 × 50	276		70		103	
75 × 65	275		87		95	
100 × 16	298		36		116	
100 × 20	298		36		111	
100 × 25	303		42		111	
100 × 30	304		48		110	
100 × 40	309	152	58	68	109	
100 × 50	314		70		109	
100 × 65	327		87		115	
100 × 75	335		102		119	

特殊継手エスロンユニフィット ESLON "UNIFIT" COMPACT FITTINGS

レデュシングエルボ Reducing Elbow

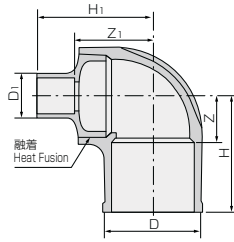

HI-PVC

単位Unit : mm

呼び径 Size	D	D ₁	H	H ₁	Z	Z ₁
65×16		31		115		85
65×20		36		120		85
65×25	87	42	110	125	49	85
65×30		48		124		82
65×40		58		140		92
75×16		36		127		97
75×20		36		127		92
75×25		42		133		93
75×30	102	48	120	133	56	91
75×40		58		148		100
75×50		70		156		103
75×65		87		155		95
100×16		36		149		119
100×20		36		149		114
100×25		42		154		114
100×30		48		155		113
100×40	130	58	155	160	71	112
100×50		70		165		112
100×65		87		178		118
100×75		102		186		122

サンプリングチーズ Sampling Tee

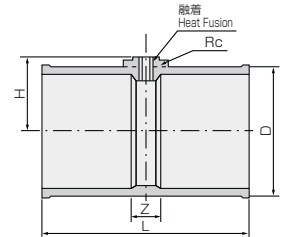

HI-PVC

単位Unit : mm

呼び径 Size	L	H	D	Z	ねじ径 Thread Size
65	145	54	87	23	Rc1/4 3/8
75	155	64	102	27	Rc1/4 3/8
100	200	79	130	32	Rc1/4 3/8
125	240	90	157	32	Rc1/4 3/8 1/2
150	300	106	186	36	Rc1/4 3/8 1/2

レジューサー Reducing Coupling

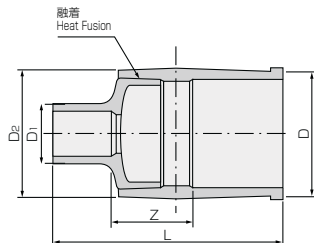

HI-PVC

単位Unit : mm

呼び径 Size	L	D	D ₁	D ₂	Z
65×16	150		31		59
65×20	155		36		59
65×25	160	87	42	88	59
65×30	159		48		56
65×40	175		58		66
75×16	162		36		68
75×20	162		36		63
75×25	168	102	42	103	64
75×30	168		48		62
75×40	183		58		71
100×16	194		36		80
100×20	194		36		75
100×25	199		42		75
100×30	200	130	48	132	74
100×40	205		58		73
100×50	210		70		73
100×65	223		87		79

■ユニフィットの使用圧力と温度の関係
Maximum Working Pressure-Temperature Rating

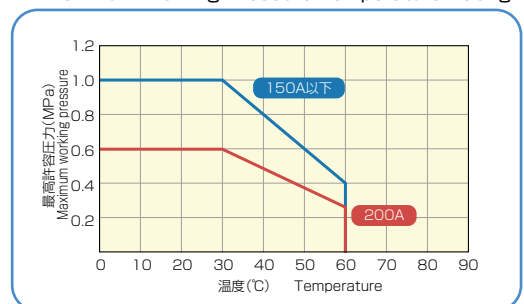

継手 FITTINGS

フランジ FLANGE

フランジ寸法は JIS B 2220 に準じます。
The flange dimensions are in accordance with JIS B 2220.

TSフランジ JIS10K

TS Flange JIS10K

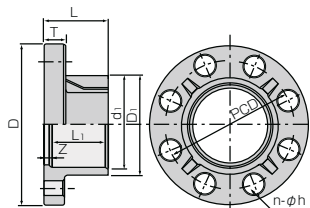

13~150

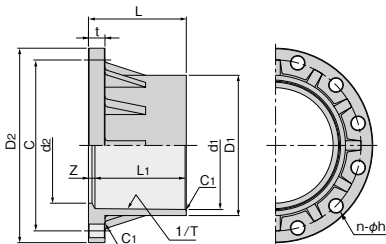

200~300

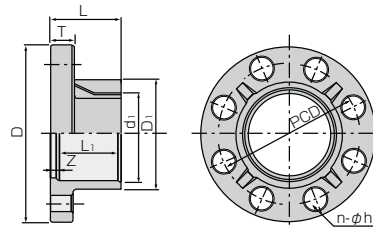

15~150

HI-PVC

単位Unit : mm

呼び径 Size		d ₁	L ₁	D ₁	L	Z	PCD	D	T	n-φh	重量 Weight (kg)
A	B										
13	3/8	18.4	26	26	31	5	65	90	14	4-15	0.120
15	1/2	22.4	30	31	35	5	70	95	14	4-15	0.130
20	3/4	26.5	35	35	40	5	75	100	14	4-15	0.150
25	1	32.6	40	42	45	5	90	125	14	4-19	0.235
30	1-1/4	38.6	44	48	50	6	100	135	16	4-19	0.310
40	1-1/2	48.7	55	61	61	6	105	140	16	4-19	0.360
50	2	60.5	63	73	70	7	120	155	20	4-19	0.520
65	2-1/2	76.5	61	88	70	9	140	175	22	4-19	0.710
80	3	89.6	64	102	72	8	150	185	22	8-19	0.745
100	4	114.7	84	132	90	6	175	210	22	8-19	1.140
125	5	140.9	104	158	114	10	210	250	24	8-23	1.670
150	6	166.0	132	186	142	10	240	280	26	8-23	2.530
200	8	217.5	155	238	166	11	290	330	28	12-23	3.540
※200	8	217.5	130	238	141	11	290	330	28	12-23	3.250
250	10	269	185	289	198	13	355	400	30	12-25	5.470
300	12	319	185	344	203	18	400	445	32	16-25	8.000

※融着用継手です。L, L₁寸法が短くなります。※Butt spigot flange

HT(C-PVC)

単位Unit : mm

呼び径 Size		d ₁	L ₁	D ₁	L	Z	PCD	D	T	n-φh	重量 Weight (kg)
A	B										
15	1/2	22	30	31	35	5	70	95	14	4-15	0.130
20	3/4	26	35	35	40	5	75	100	14	4-15	0.150
25	1	32	40	42	45	5	90	125	14	4-19	0.230
30	1-1/4	38	44	48	50	6	100	135	16	4-19	0.320
40	1-1/2	48	55	61	61	6	105	140	16	4-19	0.360
50	2	60	63	73	70	7	120	155	20	4-19	0.580
65	2-1/2	76	61	88	70	9	140	175	22	4-19	0.780
80	3	89	64	102	72	8	150	185	22	8-19	0.820
100	4	114	84	132	92	8	175	210	22	8-19	1.200
125	5	140	104	158	114	10	210	250	24	8-23	1.700
150	6	166	132	186	142	10	240	280	26	8-23	2.525

TSルーズフランジ TS Loose Flange JIS 10K

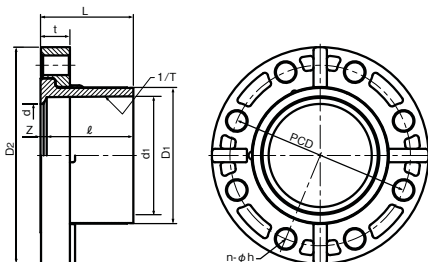

HI-PVC

単位Unit : mm

呼び径 Size		d ₁	ℓ	1/T	D ₁	d	D ₂	PCD	t	n-φh	L	Z	重量 Weight (kg)
A	B												
15	1/2	22.4	30	1/34	31	17	95	70	21	4-15	36	6	0.130
20	3/4	26.5	35	1/34	35	21	100	75	21	4-15	41	6	0.150
25	1	32.6	40	1/34	41	25	125	90	21	4-19	46	6	0.240
30	1 1/4	38.6	44	1/34	48	31	135	100	23	4-19	51	7	0.310
40	1 1/2	48.7	55	1/37	61	41	140	105	23	4-19	62	7	0.360
50	2	60.8	63	1/37	73	52	155	120	25	4-19	70	7	0.450
65	2 1/2	76.6	61	1/48	88	67	175	140	25	4-19	70	9	0.560
80	3	89.6	64	1/49	102	78	185	150	27	8-19	72	8	0.640
100	4	114.7	84	1/56	132	100	210	175	28	8-19	90	6	0.930
125	5	140.9	104	1/58	158	125	250	210	28	8-23	114	10	1.350
150	6	166.0	132	1/63	186	146	280	240	32	8-23	142	10	2.060
200	8	217.5	155	1/50	238	196	330	290	36	12-23	166	11	3.020
※200	8	217.5	130	1/50	238	196	330	290	36	12-23	141	11	2.730

※融着用継手です。L, ℓ寸法が短くなります。※Butt spigot flange

板フランジ Blind Flange JIS10K

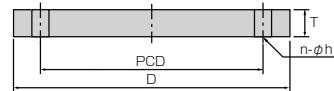

HI-PVC

単位Unit : mm

呼び径 Size		D	PCD	T	n-φh	重量 Weight (kg)
A	B					
15	1/2	95	70	12	4-15	0.113
20	3/4	100	75	14	4-15	0.135
25	1	125	90	14	4-19	0.229
30	1-1/4	135	100	16	4-19	0.310
40	1-1/2	140	105	16	4-19	0.335
50	2	155	120	16	4-19	0.417
65	2-1/2	175	140	18	4-19	0.606
80	3	185	150	18	8-19	0.651
100	4	210	175	18	8-19	0.856
125	5	250	210	20	8-23	1.345
150	6	280	240	22	8-23	1.884
200	8	330	290	22	12-23	2.605
250	10	400	355	24	12-25	4.021
300	12	445	400	24	16-25	4.665

最高許容圧力 Max Working Pressure

単位Unit : MPa

サイズ	HI-PVC
15-100A	1.0
125-150A	0.8
200A	0.5
250A	0.4
300A	0.3

継手 FITTINGS

ユニオン継手 TRUE UNION

コンパクトタイプ (TSソケット、PVDF変換継手)

Compact Type (TS Socket, PVDF Transition Fitting)

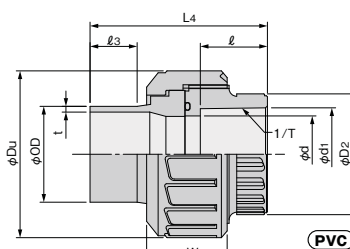
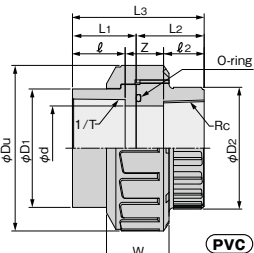
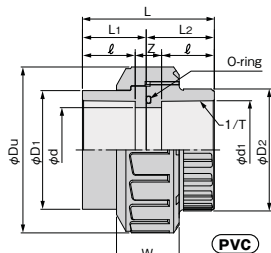

PVC, HT(C-PVC) Oリング : EPDM or FKM

呼び径 Size	TS受口 TS Socket (PVC,HT)	ねじ受口 Thread (PVC)	融着受口 Butt (PVDF)	単位 Unit : mm																		
A	B	d ₁	1/T	Z	L	Rc	Z	ℓ ₂	L ₃	φOD	t	ℓ ₃	L ₄	ℓ	L ₁	L ₂	d	Du	D ₁	D ₂	W	Oリング O-ring
13	3/8	18.3	1/30	6	42	3/8	11	13	42	-	-	-	-	18	20	22	13	40	24	26	17	P-16
16	1/2	22.3	1/37	8	52	1/2	14	16	52	20	1.9	30	72	22	25	27	15	46	30	32	20	P-20
20	3/4	26.3	1/42	9	59	3/4	17	17	59	25	1.9	24	76	25	28	31	20	54	35	37	23	P-24
25	1	32.3	1/44	9	67	1	17	21	67	32	2.4	24	81	29	32	35	25	67	43	45	28	P-30
30	1 1/4	38.4	1/37	12	76	1 1/4	22	22	76	40	2.4	25	85	32	36	40	31	78	53	55	31	P-36
40	1 1/2	48.5	1/38	12	82	1 1/2	25	22	82	50	3.0	24	93	35	39	43	40	87	61	63	42	P-46
50	2	60.6	1/34	16	92	2	31	23	92	63	3.0	28	104	38	43	49	51	107	76	78	43	P-58
65	2 1/2	76.6	1/38	18	108	2 1/2	32	31	108	-	-	-	-	45	52	56	65	128	90	93	50	P-71
75	3	89.6	1/40	24	120	3	39	33	120	-	-	-	-	48	58	62	77	151	108	111	57	P-85
100	4	114.7	1/42	36	152	4	59	35	152	-	-	-	-	58	72	80	100	185	132	136	72	P-112

*1:TSソケットは融着できません。 *1:TS socket cannot be used for fusion process.
*2:HT(C-PVC)は、16A以上の品揃えです。 *2:HT(C-PVC):16A~100A

ボールバルブ互換タイプ

True Union Ball Valve Compatible Type

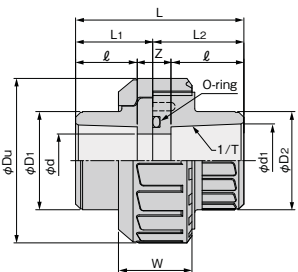

PVC, HT(C-PVC) Oリング : EPDM or FKM

呼び径 Size	TS受口部 TS Socket	単位 Unit : mm																
A	B	d ₁	1/T	ℓ	L	L ₁	L ₂	Z	d	Du	D ₁	D ₂	W	Oリング O-ring				
16	1/2	22.3	1/37	23	59	29	30	13	16	49	33	31	24	P-20				
20	3/4	26.3	1/42	26	68	35	33	16	20	59	35	36	26	P-24				
25	1	32.3	1/43	29	78	36	42	20	25	68	44	44	31	P-30				
30	1 1/4	38.4	1/37	32	90	44.5	45.5	26	30	80	54	54	31	P-36				
40	1 1/2	48.5	1/38	35	94	42	52	24	40	98	65	67	40	P-48A				
50	2	60.6	1/34	38	110	48	61	34	50	120	77	79	43	P-56				

他のユニオン製品との互換性 Compatibility of True Union

ユニオン継手 コンパクトタイプ True Union Compact Type	× 互換性なし Compatibility	ユニオン継手ボールバルブ互換タイプ True Union Ball Valve Compatible Type	ユニオン継手 コンパクトタイプ True Union Compact Type	× 互換性なし Compatibility	ユニオン継手ボールバルブ互換タイプ True Union Ball Valve Compatible Type
	× 互換性なし Compatibility	エスロンボールバルブユニオン式 Ball Valve Union Type		× 互換性なし Compatibility	エスロンボールバルブユニオン式 Ball Valve Union Type
	× 互換性なし Compatibility	エスロンダイヤフラムバルブユニオン式 Diaphragm Valve Union Type		× 互換性あり Compatibility	エスロンダイヤフラムバルブユニオン式 Diaphragm Valve Union Type

*ねじ変換タイプは、PVCのみの品揃えです。 *Thread type is available only with PVC.

エスロンサドルバンド ESLON SADDLE BAND

*クリーンではありません。

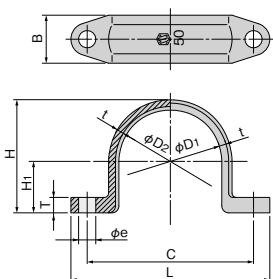

PVC

呼び径 Size	φD ₁	φD ₂	t	C	L	φe	T	H ₁	H	B	使用ボルト Bolt
16	22	24	3	42	53	6	5	11	26	15	M5
20	26	29	3	48	59	6	5	13	30.5	18	M5
25	32	35	3	54	65	6	6	16	36.5	18	M5
28	34	37	3	59	73	7	7	17	38.5	20	M6
30	38	41	4	66	80	7	7	19	43.5	20	M6
40	48	52	4	90	109	10	9	24	54	25	M8
50	60	64	4	97	116	10	9	30	66	28	M8
65	76	81	4	114	134	10	10	38	82.5	30	M8
75	89	94	4	134	158	12	11	44.5	95.5	38	M10
100	114	120	4.5	160	186	12	12	57	121.5	42	M10
125	140	150	5	192	218	12	12	70	150	46	M10
150	165	177	8	238	268	17	14	82.5	179	50	M14
200	216	236	10	316	356	18	20	108	236	70	M16

エスロンクリーンヘッダー ESLON CLEAN HEADER

ねじタイプ Thread Type

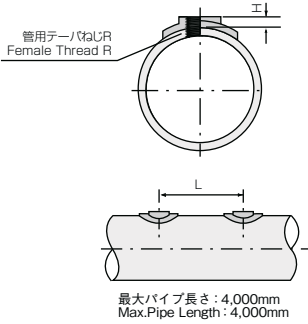

※L: 主管サイズでの分岐の最小ピッチ
L: Minimum Pitch of branch for main pipe

HI-PVC 単位Unit: mm

呼び径Size	L	H
40 × Rc1/4	40	12
40 × Rc3/8	40	12
50 × Rc1/4	60	9
50 × Rc3/8	60	9
50 × Rc1/2	60	9
50 × Rc3/4	60	9
65 × Rc1/4	70	11
65 × Rc3/8	70	11
65 × Rc1/2	70	11
65 × Rc3/4	70	11
75 × Rc1/4	70	11
75 × Rc3/8	70	11
75 × Rc1/2	70	11
75 × Rc3/4	70	11
100 × Rc1/4	70	11
100 × Rc3/8	70	11
100 × Rc1/2	70	11
100 × Rc3/4	70	11
125 × Rc1/4	75	12
125 × Rc3/8	75	12
125 × Rc1/2	75	12
125 × Rc3/4	75	12
125 × Rc1	75	12
150 × Rc1/4	75	12
150 × Rc3/8	75	12
150 × Rc1/2	75	12
150 × Rc3/4	75	12
150 × Rc1	75	12
200 × Rc1/4	75	14
200 × Rc3/8	75	14
200 × Rc1/2	75	14
200 × Rc3/4	75	14
200 × Rc1	75	14

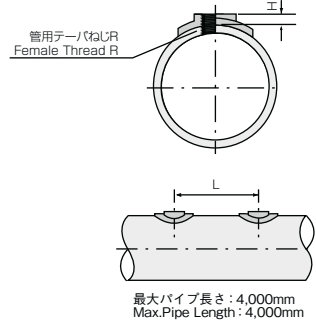

※L: 主管サイズでの分岐の最小ピッチ
L: Minimum Pitch of branch for main pipe

HT(C-PVC) 単位Unit: mm

呼び径Size	L	H
40 × Rc1/4	40	12
40 × Rc3/8	40	12
50 × Rc1/4	60	9
50 × Rc3/8	60	9
50 × Rc1/2	60	9
50 × Rc3/4	60	9
65 × Rc1/4	70	11
65 × Rc3/8	70	11
65 × Rc1/2	70	11
65 × Rc3/4	70	11
75 × Rc1/4	70	11
75 × Rc3/8	70	11
75 × Rc1/2	70	11
75 × Rc3/4	70	11
100 × Rc1/4	70	11
100 × Rc3/8	70	11
100 × Rc1/2	70	11
100 × Rc3/4	70	11
125 × Rc1/4	75	12
125 × Rc3/8	75	12
125 × Rc1/2	75	12
125 × Rc3/4	75	12
125 × Rc1	75	12
150 × Rc1/4	75	12
150 × Rc3/8	75	12
150 × Rc1/2	75	12
150 × Rc3/4	75	12
150 × Rc1	75	12

TSソケットタイプ TS Socket Type

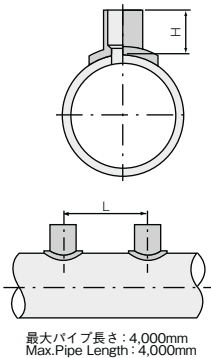
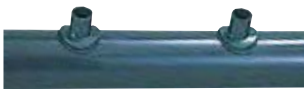

※L: 主管サイズでの分岐の最小ピッチ
L: Minimum Pitch of branch for main pipe

HI-PVC 単位Unit: mm

呼び径Size	L	H
50 × 13	60	40
50 × 16	60	40
50 × 20	60	45
50 × 25	60	50
65 × 13	70	40
65 × 16	70	40
65 × 20	70	45
65 × 25	80	50
65 × 30	80	54
75 × 13	70	40
75 × 16	70	40
75 × 20	70	45
75 × 25	80	50
75 × 30	80	54
75 × 40	90	65
100 × 13	70	40
100 × 16	70	40
100 × 20	70	45
100 × 25	80	50
100 × 30	80	54
100 × 40	90	65
100 × 50	110	73
125 × 13	70	40
125 × 16	70	40
125 × 20	70	45
125 × 25	80	50
125 × 30	80	54
125 × 40	90	65
125 × 50	120	73
200 × 13	70	40
200 × 16	70	40
200 × 20	70	45
200 × 25	80	50
200 × 30	80	54
200 × 40	90	65
200 × 50	120	73

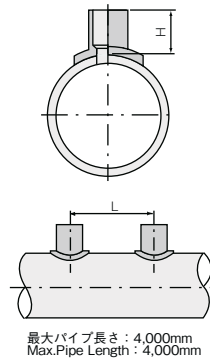

※L: 主管サイズでの分岐の最小ピッチ
L: Minimum Pitch of branch for main pipe

HT(C-PVC) 単位Unit: mm

呼び径Size	L	H
50 × 16	60	40
50 × 20	60	45
50 × 25	60	50
65 × 16	70	40
65 × 20	70	45
65 × 25	80	50
65 × 30	80	54
75 × 16	70	40
75 × 20	70	45
75 × 25	80	50
75 × 30	80	54
75 × 40	90	65
100 × 16	70	40
100 × 20	70	45
100 × 25	80	50
100 × 30	80	54
100 × 40	90	65
100 × 50	110	73
125 × 16	70	40
125 × 20	70	45
125 × 25	80	50
125 × 30	80	54
125 × 40	90	65
125 × 50	120	73
150 × 16	70	40
150 × 20	70	45
150 × 25	80	50
150 × 30	80	54
150 × 40	90	65
150 × 50	120	73
150 × 65	150	82

■クリーンヘッダーの使用圧力と温度の関係 Maximum Working Pressure-Temperature Rating

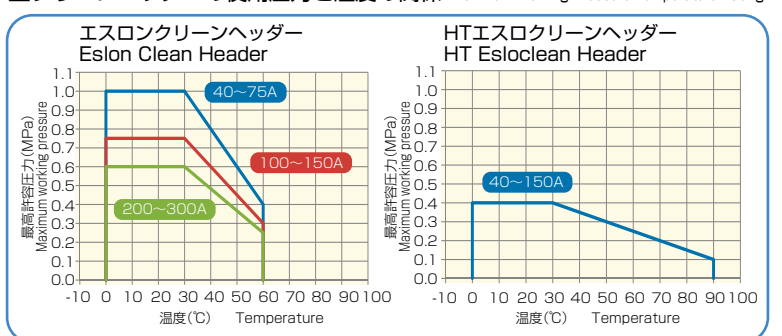

パッキン GASKET

エスロンPTFEパッキン ESLON PTFE GASKET

JIS10K

JIS10K

単位Unit : mm

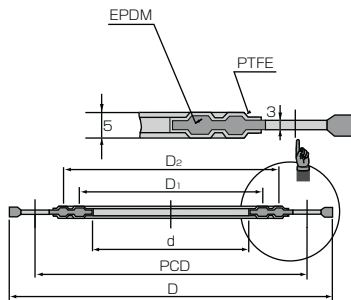

呼び径 Size	d	D ₁	D ₂	PCD	D	n-φh	推奨締付トルク N·m(kgf·cm) Recommend Fasten Torqu
13	14	23	37	65	88	4-15	16{160}
15	18	26	41	70	93	4-15	16{160}
20	22	36	46	75	98	4-15	16{160}
25	30	38	53	90	123	4-19	34{340}
30	37	50	65	100	133	4-19	34{340}
40	43	54	69	105	138	4-19	34{340}
50	54	68	83	120	153	4-19	34{340}
65	69	86	101	140	173	4-19	51{510}
80	80	98	113	150	183	8-19	51{510}
100	102	120	138	175	208	8-19	51{510}
125	127	145	168	210	248	8-23	62{620}
150	150	168	190	240	278	8-23	62{620}
200	198	216	248	290	328	12-23	62{620}
250	250	270	306	355	398	12-25	73{730}
300	300	324	356	400	443	16-25	73{730}

エスロンEPDMパッキン ESLON EPDM GASKET

JIS10K

JIS10K

単位Unit : mm

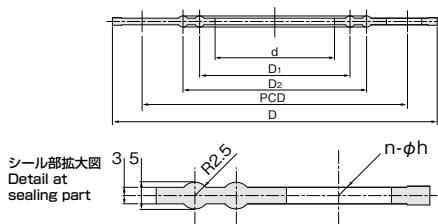

呼び径 Size	d	D ₁	D ₂	PCD	D	n-φh	推奨締付トルク N·m(kgf·cm) Recommend Fasten Torqu
13	17	25	38	65	88	4-15	15{150}
15	20	28	42	70	93	4-15	15{150}
20	25	33	47	75	98	4-15	15{150}
25	30	38	53	90	123	4-19	30{300}
30	38	48	63	100	133	4-19	30{300}
40	46	54	69	105	138	4-19	30{300}
50	58	68	83	120	153	4-19	30{300}
65	73	86	101	140	173	4-19	45{450}
80	84	98	113	150	183	8-19	45{450}
100	106	120	138	175	208	8-19	45{450}
125	131	145	168	210	248	8-23	55{550}
150	155	170	196	240	278	8-23	55{550}
200	204	218	248	290	328	12-23	55{550}
250	254	270	306	355	398	12-25	65{650}
300	304	324	356	400	443	16-25	65{650}
350	352	368	400	445	488	16-25	65{650}

■ クリーンパイプ・クリーン継手の使用圧力と温度の関係 Maximum Working Pressure-Temperature Rating

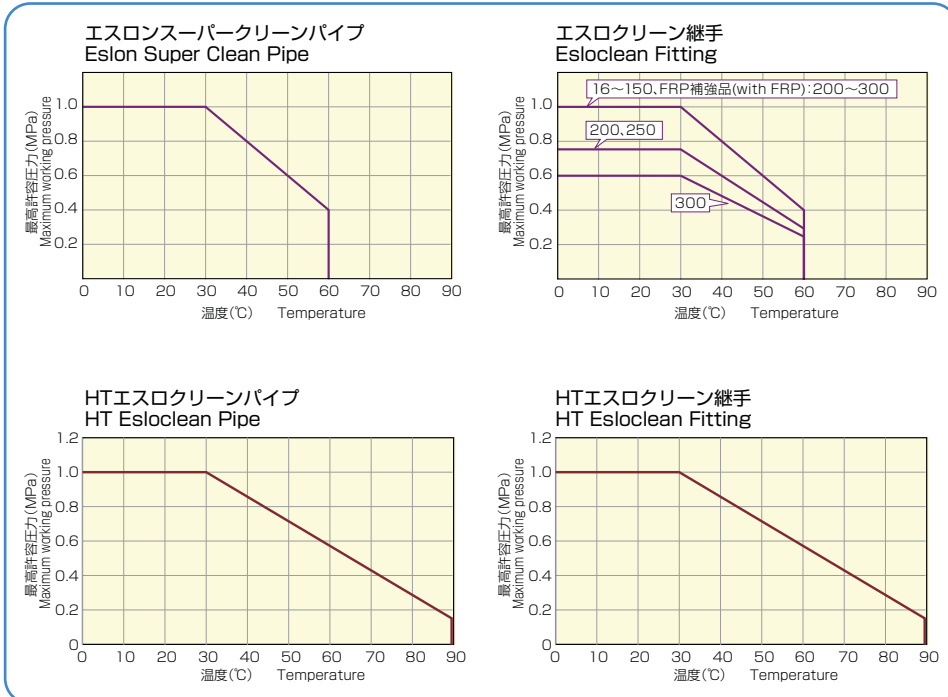

エスロンPVDF-UHP パイプシステム Eslon PVDF-UHP PIPE SYSTEM

エスロン®PVDF-UHP配管材料は、高純度で、耐食性に優れたふっ素樹脂配管材料です。

Eslon PVDF-UHP Pipes & Fittings are Excellent in Ultra High Purity and Chemical Resistance.



材質 Material	サイズ Size	使用温度 Usable Temperature	最高許容圧力 Max. Working Pressure	接続方式 Joint	用途 Method
PVDF-UHP	15~200	-20℃~+120℃	1.0MPa	バット融着 Butt Fusion Type	超純水&熱滅菌 Ultrapure Process Heat Sterilization

特長 Advantage

■無添加PVDFのためTOC、金属の溶出が極めて少ない。

Extremely little elution of heavy metal or TOC, because PVDF-UHP pipes & fittings are made from high purity PVDF material that does not contain stabilizer, lubricants, additive and pigment at all.

■溶出性能

Elution Performance

単位 Unit	TOC	Ca	Mg	Na
μg/m ² ·day	3.0	0.35	<0.003	<0.003

※半導体基盤技術研究会提唱の短管封水試験法による8~30日の測定値
Data for 8-30 days by the UCT/Japan test method

■管内面の表面粗さは平滑で、生菌の増殖やコンタミを防止します。

The inside surface of pipe is finished very smooth like mirror, then it prevents proliferation and contamination.

■平滑性能

Smoothness of Internal Pipe Surface

単位 Unit	エスロン®PVDF-UHP	Eslon PVDF-UHP
Pt(μm)	0.25	

※実測値であり、保証値ではありません。
This data is intended to serve as reference.



電顕写真
Micro Scope Photograph of the inside surface of PVDF-UHP pipe

■配管の接合は熱溶着のため、接着接合のような溶出物がありません。

Extremely little elution in comparison with solvent joint, because of butt welding joining.



溶着接合部
Photograph of butt Fusion joint

■耐薬品性、耐熱性、機械的強度に優れています。

Excellent chemical resistance, high working temperature up to 120℃ and mechanical properties.

パイプ PIPE

パイプ Pipe

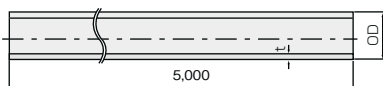

PN16 単位Unit: mm

呼び径 Size	OD	t	重量 Weight (kg/m)
15	20	1.9	0.210
20	25	1.9	0.270
25	32	2.4	0.440
32	40	2.4	0.550
40	50	3.0	0.850
50	63	3.0	1.090
65	75	3.6	1.550
80	90	4.3	2.220
100	110	5.3	3.320
125	140	6.7	5.310
150	160	7.7	6.960
200	225	10.8	13.670

PN10 単位Unit: mm

呼び径 Size	OD	t	重量 Weight (kg/m)
80	90	2.8	1.480
100	110	3.4	2.200
125	140	4.3	3.520
150	160	4.9	4.540
200	225	6.9	8.950

継手 FITTINGS

マルチベンド90° Bend 90°

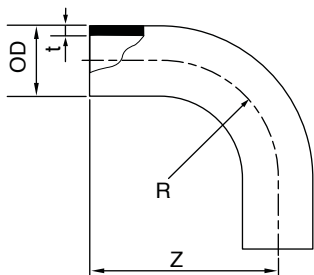

PN16 単位Unit: mm

呼び径 Size	OD	Z	R	t	重量 Weight (kg)
15	20	51	20	1.9	0.021
20	25	56	25	1.9	0.027
25	32	63	32	2.4	0.052
32	40	72	40	2.4	0.073
40	50	84	50	3.0	0.123
50	63	97	63	3.0	0.200
65	75	100	75	3.6	0.306
80	90	123	90	4.3	0.517
100	110	142	110	5.3	0.912
125	140	216	140	6.7	2.020
150	160	236	160	7.7	2.840
200	225	301	225	10.8	7.250

PN10 単位Unit: mm

呼び径 Size	OD	Z	R	t	重量 Weight (kg)
80	90	123	90	2.8	0.396
100	110	142	110	3.4	0.660
125	140	216	140	4.3	1.477
150	160	236	160	4.9	1.990
200	225	301	225	6.9	5.080

45°エルボ Elbow 45°

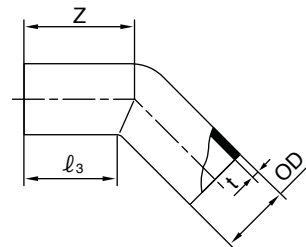

PN16 単位Unit: mm

呼び径 Size	OD	l ₃	Z	t	重量 Weight (kg)
15	20	39	43	1.9	0.023
20	25	40	45	1.9	0.029
25	32	46	52	2.4	0.053
32	40	50	58	2.4	0.069
40	50	56	66	3.0	0.114
50	63	62	75	3.0	0.174
65	75	32	50	3.0	0.151
80	90	36	59	4.3	0.240
100	110	45	68	5.3	0.458
125	140	57	85	6.7	0.997
150	160	65	103	7.7	1.450

PN10 単位Unit: mm

呼び径 Size	OD	l ₃	Z	t	重量 Weight (kg)
80	90	36	59	2.8	0.174
100	110	45	68	3.4	0.309
125	140	57	85	4.3	0.638
150	160	65	103	4.9	0.988

継手 FITTINGS

同径チーズ Tee

Tee

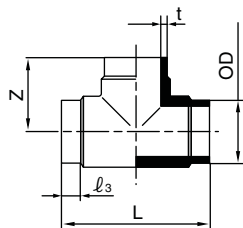

PN16 単位Unit: mm

呼び径 Size	OD	L	Z	l ₃	t	重量 Weight (kg)
15	20	75	38	25	1.9	0.022
20	25	84	42	25	1.9	0.036
25	32	90	46	25	2.4	0.059
32	40	116	58	31	2.4	0.096
40	50	126	64	31	3.0	0.154
50	63	140	70	31	3.0	0.217
65	75	178	89	42	3.6	0.365
80	90	185	92	33.5	4.3	0.608
100	110	221	110	33.5	5.3	1.150
125	140	308	154	60	6.7	2.290
150	160	279	140	45	7.7	2.677
200	225	496	246	99	10.8	9.205

PN10 単位Unit: mm

呼び径 Size	OD	L	Z	l ₃	t	重量 Weight (kg)
80	90	185	92	33.5	2.8	0.457
100	110	221	110	33.5	3.4	0.866
125	140	308	154	60	4.3	1.768
150	160	279	140	45	4.9	1.914
200	225	496	246	99	6.9	6.940

異径チーズ Reducing Tee

Reducing Tee

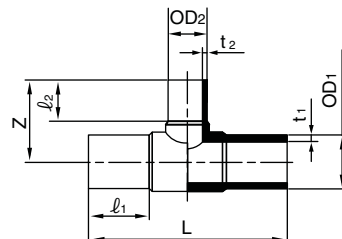

PN16 単位Unit: mm

呼び径 Size	OD ₁ /OD ₂	L	l ₁	l ₂	z	t ₁ /t ₂	重量 Weight (kg)
50×25	63/32	149	28	27	74	3.0/2.4	0.221
80×50	90/63	230	75	65	95	4.3/3.0	0.689
100×50	110/63	230	85	65	105	5.3/3.0	0.990
100×80	110/90	313	87	75	150	5.3/4.3	1.370
150×50	160/63	345	100	65	175	7.7/3.0	2.800
150×80	160/90	348	97	70	183	7.7/4.3	3.260
150×100	160/110	349	96	80	183	7.7/5.3	3.458

PN10 単位Unit: mm

呼び径 Size	OD ₁ /OD ₂	L	l ₁	l ₂	z	t ₁ /t ₂	重量 Weight (kg)
100×80	110/90	313	87	75	150	3.4/2.8	1.070
150×100	160/110	349	97	81	183	4.9/3.4	2.820

PN10/PN16 単位Unit: mm

呼び径 Size	OD ₁ /OD ₂	L	l ₁	l ₂	z	t ₁ /t ₂	重量 Weight (kg)
80×50	90/63	230	53	38	95	2.8/3.0	0.581
100×50	110/63	315	85	65	150	3.4/3.0	1.030
150×50	160/63	348	100	65	175	4.9/3.0	2.125
150×80	160/90	348	97	72	183	4.9/4.3	2.655
150×100	160/110	347	96	81	185	4.9/5.3	2.950

キャップ End Cap

End Cap

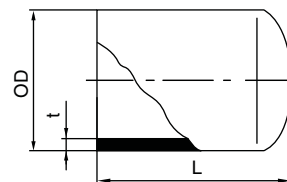

PN16 単位Unit: mm

呼び径 Size	OD	L	t	重量 Weight (kg)
15	20	48	1.9	0.011
20	25	48	1.9	0.013
25	32	52	2.4	0.024
32	40	60	2.4	0.036
40	50	64	3.0	0.059
50	63	69	3.0	0.085
65	75	93	3.6	0.175
80	90	110	4.3	0.298
100	110	125	5.3	0.454

PN10 単位Unit: mm

呼び径 Size	OD	L	t	重量 Weight (kg)
80	90	110	2.8	0.198
100	110	125	3.4	0.300

継手 FITTINGS

クリーンパイプ
Clean Pipe

PVDF-UHPパイプ
PVDF-UHP Pipe

クリーンバルブ
Clean Valves

技術データ
Technical Data

施工
Installation

レジューサ

Reducing coupling

オネジアダプタ

Adaptor with Male Thread

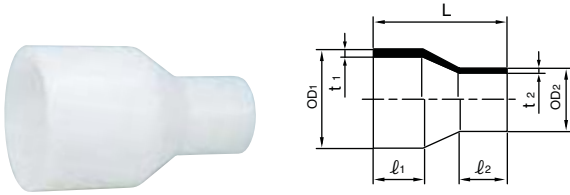

PN16 単位Unit : mm

呼び径 Size	OD1/OD2	L	l ₁	l ₂	t ₁ t ₂	重量 Weight (kg)
20×15	25/20	50	20	20	1.9/1.9	0.012
25×15	32/20	50	18.5	19	2.4/1.9	0.017
25×20	32/25	50	20	20	2.4/1.9	0.024
32×15	40/20	55	20	20	2.4/1.9	0.022
32×20	40/25	55	20	20	2.4/1.9	0.023
32×25	40/32	55	20	20	2.4/2.4	0.026
40×15	50/20	60	23	20	3.0/1.9	0.036
40×20	50/25	60	24	20	3.0/1.9	0.039
40×25	50/32	60	25	20	3.0/2.4	0.043
40×32	50/40	60	25	22	3.0/2.4	0.049
50×25	63/32	65	25	18	3.0/2.4	0.060
50×32	63/40	65	26	22	3.0/2.4	0.061
50×40	63/50	65	25	24	3.0/3.0	0.068
65×40	75/50	148	63	57	3.6/3.0	0.205
65×50	75/63	149	65	60	3.6/3.0	0.212
80×50	90/63	160	70	59	4.3/3.0	0.274
80×65	90/75	162	75	62	4.3/3.6	0.308
100×50	110/63	103	30	33	5.3/3.0	0.238
100×80	110/90	90	30	35	5.3/4.3	0.254
125×50	140/63	133	38	27	6.7/3.0	0.503
125×100	140/110	110	42	40	6.7/5.3	0.480
150×100	160/110	230	95	89	7.7/5.3	1.240
150×125	160/140	226	95	96	7.7/6.7	1.434
200×150	225/160	160	32	35	10.8/7.7	1.690

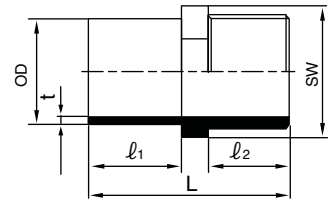

PN10 単位Unit : mm

呼び径 Size	OD	L	l ₁	l ₂	t	SW	重量 Weight (kg)
15	20	46	20	18	1.9	22	0.014
20	25	51	23	20	1.9	27	0.023
25	32	61	29	23	2.4	36	0.035
32	40	66	29	27	2.4	46	0.072
40	50	74	33	29	3.0	55	0.098
50	63	80	35	31	3.0	65	0.133

メネジアダプタ

Adaptor with Female Thread

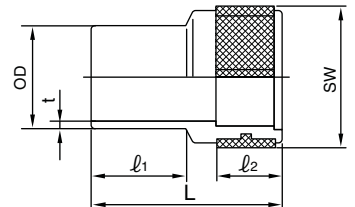

PN10 単位Unit : mm

呼び径 Size	OD1/OD2	L	l ₁	l ₂	t ₁ t ₂	重量 Weight (kg)
100×80	110/90	90	30	35	3.4/2.8	0.196
125×100	140/110	110	42	40	4.3/3.4	0.345
150×100	160/110	222	95	89	4.9/3.4	0.900
150×125	160/140	226	95	96	4.9/4.3	1.023
200×150	225/160	160	32	35	6.9/4.9	1.196

PN10/PN16 単位Unit : mm

呼び径 Size	OD1/OD2	L	l ₁	l ₂	t ₁ t ₂	重量 Weight (kg)
80×50	90/63	160	70	59	2.8/3.0	0.246
100×50	110/63	103	30	33	3.4/3.0	0.178
150×100	160/110	230	95	89	4.9/5.3	1.215

PN10 単位Unit : mm

呼び径 Size	OD	L	l ₁	l ₂	t	SW	重量 Weight (kg)
15	20	46	20	16	1.9	32	0.025
20	25	51	23	18	1.9	41	0.046
25	32	58	29	20	2.4	46	0.059
32	40	62	30	24	2.4	55	0.090
40	50	68	34	24	3.0	70	0.166
50	63	75	35	28	3.0	85	0.246

継手 FITTINGS

スタブフランジ

Stub Flange JIS 10K

バックリング JIS10K

Backing Ring JIS10K

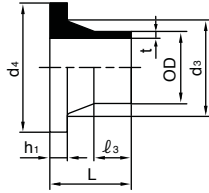

PN16 単位Unit: mm

呼び径 Size	OD	L	l ₃	t	d ₃	d ₄	h ₁	重量 Weight (kg)
15	20	49	31	1.9	27	45	6	0.029
20	25	50	30	1.9	33	58	6.5	0.042
25	32	50	26	2.4	40	68	7	0.064
32	40	50	24	2.4	50	78	8	0.082
40	50	50	22	3.0	61	84	9	0.115
50	63	50	19.5	3.0	76	99	10	0.165
65	75	50	20	3.6	89	119	10	0.236
80	90	80	42	4.3	105	129	11	0.374
100	110	80	40	5.3	125	154	12	0.521
125	140	80	42	6.7	155	185	15	0.780
150	160	81	36.5	7.7	175	212	16	1.071
200	225	100	76	10.8	235	265	20	0.868

PN10 単位Unit: mm

呼び径 Size	OD	L	l ₃	t	d ₃	d ₄	h ₁	重量 Weight (kg)
80	90	80	42	2.8	105	129	11	0.306
100	110	80	42	3.4	125	154	12	0.418
125	140	80	41	4.3	155	185	15	0.636
150	160	81	37	4.9	175	212	16	0.982
200	225	100	76	6.9	235	265	18	1.395

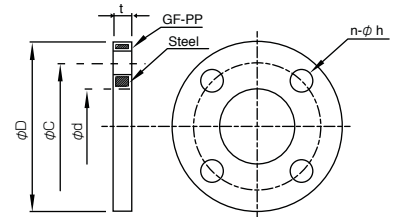
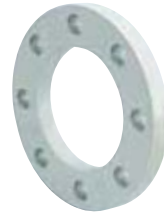

単位Unit: mm

呼び径 Size	OD	D	C	d	n-phi h	t	Bolt	重量 Weight (kg)
15	20	96	70	28	4-15	12.0	M12	0.249
20	25	100	75	34	4-15	14.0	M12	0.295
25	32	125	90	42	4-19	14.0	M16	0.480
32	40	135	100	51	4-19	14.0	M16	0.540
40	50	140	105	62	4-19	16.0	M16	0.632
50	63	159	120	78	4-19	16.0	M16	0.767
65	75	175	139	92	4-19	16.0	M16	0.902
80	90	185	150	110	8-19	18.0	M16	0.849
100	110	210	175	133	8-19	18.0	M16	0.990
125	140	250	210	158	8-23	20.0	M20	1.550
150	160	280	240	178	8-23	22.0	M20	2.530
200	225	330	290	238	12-23	22.0	M20	2.550

ユニオン継手

True Union

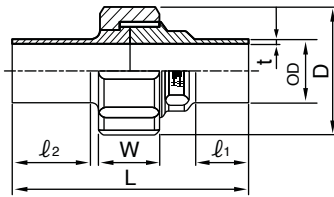

PN16 単位Unit: mm

呼び径 Size	OD	L	l ₁	l ₂	t	D	W	重量 Weight (kg)
15	20	106	27	38	1.9	43	23	0.080
20	25	112	27	40	1.9	53	25	0.120
25	32	120	27	44	2.4	60	27	0.170
32	40	124	27	47	2.4	75	30	0.260
40	50	132	27	47	3.0	82	35	0.350
50	63	137	27	47	3.0	100	37.5	0.550

クリーンバルブ CLEAN VALVES

禁油品
Oil-free

部品の状態で洗浄し、組み立てたもの(超純水仕様適合品) Clean parts of valve and assemble the parts. (Product conformed to Ultra Pure Water Specification)

洗浄品
Rinsed

バルブを組み立てた状態で洗浄液に浸漬し洗浄するもの(完全禁油ではない) Clean assembled valve immersing clean liquid(Not complete oil free)

ダイヤフラムバルブ DIAPHRAGM VALVE

禁油品
Oil-free

フランジ式 Flange

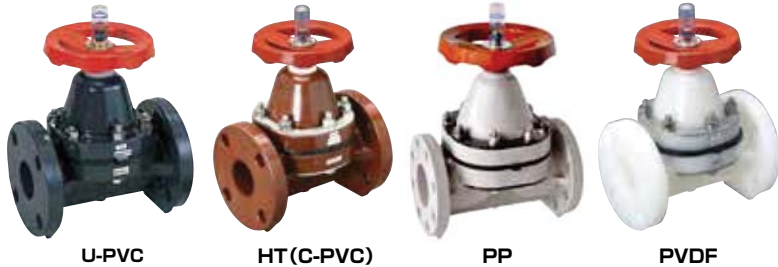

U-PVC

HT(C-PVC)

PP

PVDF

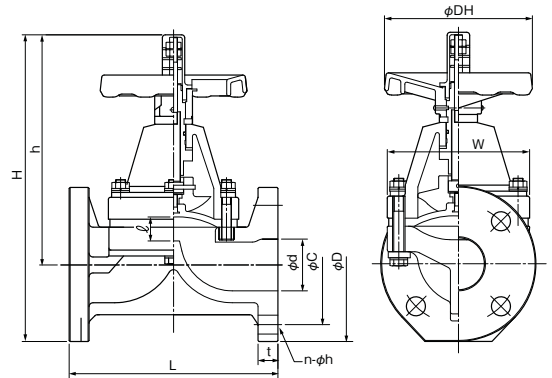

寸法表 Dimension Table

単位 Unit : mm

呼び径 Size		d	L	H	h	DH	W	ℓ	フランジ部 Flange(JIS 10K)				重量 Weight (kg)				梱包数 Q'ty/c
A	B								φD	φC	n-φh	t	U-PVC	HT(C-PVC)	PP	PVDF	
15	1/2	16	110	166	119	80	76	10	95	70	4-15	14	0.9	1.1	0.8	1.1	8
20	3/4	20	120	180	130	80	82	12	100	75	4-15	14	1.0	1.3	1.0	1.3	8
25	1	25	130	208	145	80	90	15	125	90	4-19	14	1.4	1.7	1.3	1.7	8
32	1 1/4	32	142	213	145	80	90	15	135	100	4-19	16	1.7	1.8	1.6	2.1	4
40	1 1/2	41	180	269	199	125	122	20	140	105	4-19	16	2.6	3.3	2.5	3.4	2
50	2	52	210	308	230	148	142	27	155	120	4-19	20	3.6	4.5	3.4	4.8	2
65	2 1/2	67	250	379	291	210	170	36	175	140	4-19	22	6.2	7.7	5.9	8.4	2
80	3	80	280	415	322	210	202	37	185	150	8-19	22	8.2	9.6	7.9	11.2	2
100	4	100	340	497	392	260	255	61	210	175	8-19	24	13.8	18.3	15.4	21.1	1
125	5	125	410	560	435	350	320	61	250	210	8-23	24	21.8	—	20.0	26.0	1
150	6	150	480	630	490	350	375	70	280	240	8-23	26	26.3	—	25.5	36.0	1
200	8	198	570	790	632	410	416	96	330	290	12-23	29	51.0	—	44.0	61.0	1
250	10	248	680	950	780	555	540	132	400	355	12-25	31	93.0	—	77.0	108.0	1

ねじ式・TS式・バット融着式 Thread・TS Socket・Butt Spigot

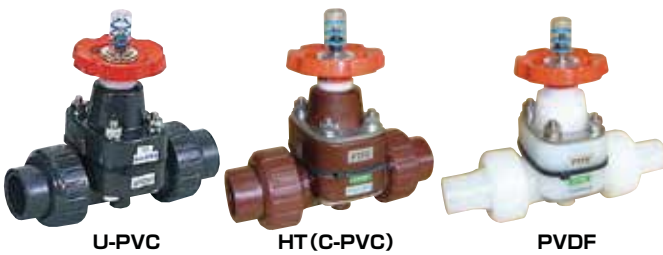

U-PVC

HT(C-PVC)

PVDF

●ねじ式
Female Thread

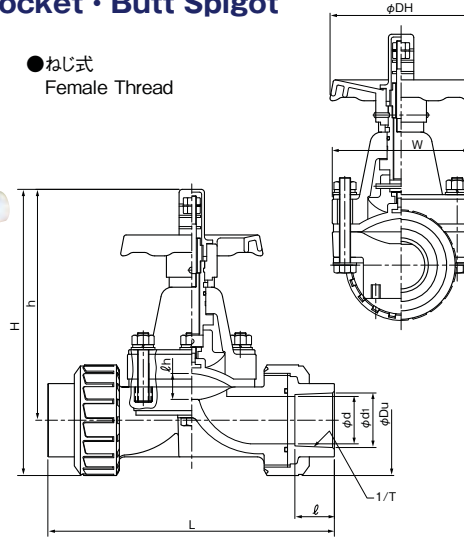

●TS式
TS Socket

●バット融着式
Butt Fused Spigot

寸法表 Dimension Table

単位 Unit : mm

呼び径 Size		d	L				H	h	DH	W				Du	ℓh	1/T	重量 Weight (kg)				梱包数 Q'ty/c				
A	B		ねじ Thread	TS	融着 Butt	ねじ・TS Thread-TS				融着 Butt	ねじ・TS Thread-TS	融着 Butt	ねじ Thread				融着 Butt	ねじ・TS Thread-TS	融着 Butt	U-PVC ねじ Thread		HT(C-PVC) TS	PVDF ねじ Thread	融着 Butt	
15	1/2	15	133	144	176	153	145	128	120	80	76	76	49	48	10	15	22	30	1/37	0.7	0.7	0.8	0.9	0.9	12
20	3/4	20	157	172	189	170	162	141	132	80	82	82	59	58	12	20	25	24	1/42	0.8	0.8	1.0	1.0	1.0	12
25	1	25	173	187	203	180	179	146	146	80	90	90	67	66	15	25	29	24	1/43	1.1	1.1	1.2	1.4	1.4	12
32	1 1/4	31	188	210	210	187	187	146	146	80	90	90	81	81	15	23	32	25	1/37	1.2	1.2	1.3	1.6	1.5	4
40	1 1/2	40	248	272	272	257	255	208	206	125	122	122	98	96	20	31	35	24	1/38	2.7	2.7	3.4	3.7	3.7	4
50	2	50	280	298	306	299	291	239	231	148	148	142	120	117	27	32	38	28	1/34	3.6	3.6	4.3	5.0	5.0	4

クリーンバルブ CLEAN VALVES

分岐ダイヤフラムバルブ DEAD SPACE FREE TEE-TYPE DIAPHRAGM VALVE

禁油品
Oil-free

分岐側フランジ式 Branch Port with Flange

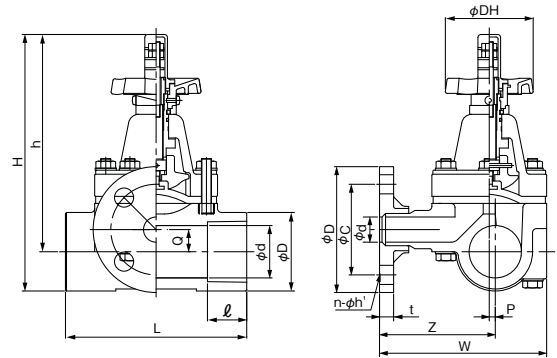

■寸法表 Dimension Table

単位 Unit : mm

呼び径 Size	L	H	h	DH	P	W	Q	Z	TS			フランジ部 Flange(JIS 10K)				重量 Weight (kg)			梱包数 Q'ty/c
									D	ℓ	d	φD	φC	n-φh'	t	U-PVC	HT(C-PVC)	PVDF	
20×16	120	148	125	80	1.5	119	8	91	35	25	21	95	70	4-15	14	0.7	0.8	—	4
25×25	120	172	152	80	3	142	8	100	44	29	25	125	90	4-19	14	1.1	1.2	1.4	1
50×25	180	261	214	90	6	166	22	115	77	30	52	125	90	4-19	14	2.5	2.8	3.7	1
65×40	240	307	259	148	6	203	30	140	96	61	67	140	105	4-19	16	3.8	4.3	4.6	1

分岐側ユニオン式 Branch Port with True Union

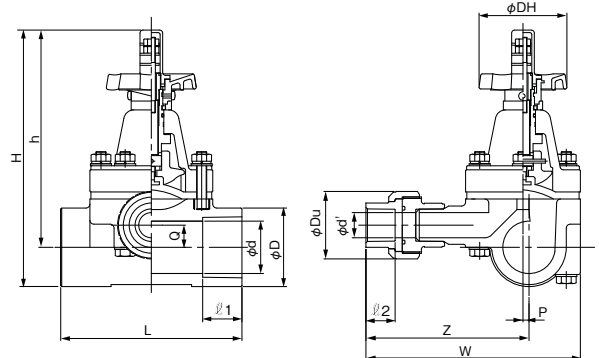

■寸法表 Dimension Table

単位 Unit : mm

呼び径 Size	L	H	h	DH	P	W	Q	Z	TS			ユニオン Union			重量 Weight (kg)			梱包数 Q'ty/c
									D	ℓ1	d	d'	ℓ2	Du	U-PVC	HT(C-PVC)	PVDF	
20×16	120	150	129	80	1.5	142	8	117	35	25	21	16	22.2	49	0.7	0.8	0.6	4
25×25	120	179	154	80	3	187	8	144	44	29	25	25	28.6	67	1.1	1.2	1.1	1
50×25	180	260	221	90	6	210	22	159	77	30	52	25	28.6	67	2.5	2.8	3.6	1
65×40	240	313	265	148	6	257	30	197	96	61	67	40	35	98	3.8	4.3	4.7	1

●バルブ接続部の寸法は、次の公的規格に準じています。
Detail dimensions of valves are in accordance with the following standards ;
フランジ Flange : JIS B 2220
ねじ Thread : JIS B 0203

●バルブの詳細については、「エスロンバルブ」カタログを参照ください。
Please refer to brochure "ESLON VALVE" for details of valves.

クリーンバルブ CLEAN VALVES

ボールバルブ BALL VALVE 禁油品 Oil-free

フランジ式 Flange

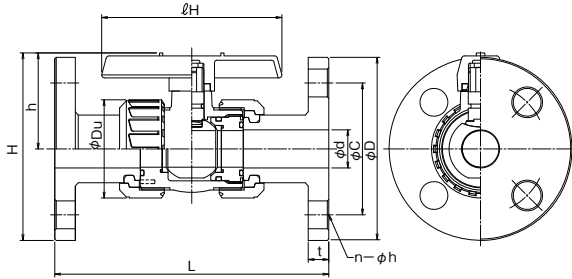
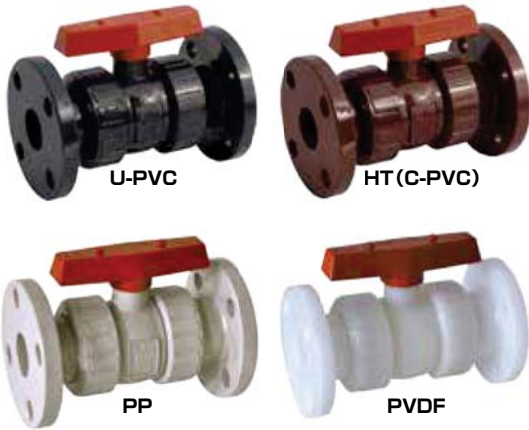

寸法表 Dimension Table

単位 Unit : mm

呼び径 Size		d	L		H	h	ℓH	Du	フランジ部 Flange (JIS 10K)				重量 Weight (kg)				梱包数 Q'ty/c
A	B		PVC,HT	PP,PVDF					φD	φC	n-φh	t	U-PVC	HT(C-PVC)	PP	PVDF	
15	1/2	15	143	143	98	50	95	49	95	70	4-15	14	0.4	0.4	0.3	0.5	12
20	3/4	20	172	172	103	53	95	59	100	75	4-15	14	0.6	0.6	0.4	0.7	12
25	1	25	187	187	129	66	123	67	125	90	4-19	14	0.9	0.9	0.5	1.0	12
32	1 1/4	30	190	190	142	74	123	81	135	100	4-19	16	1.2	1.2	0.7	1.3	12
40	1 1/2	40	212	212	170	100	152	98	140	105	4-19	16	1.7	1.7	1.1	1.9	2
50	2	50	234	234	185	107	152	120	155	120	4-19	20	2.6	2.6	1.6	3.0	2
65	2 1/2	65	259	257	222	146	188	150	175	140	4-19	22	4.2	4.3	2.8	-	2
80	3	80	309	301	262	169	230	186	185	150	8-19	22	6.7	6.9	4.4	-	2
100	4	100	372	367	317	203	283	228	210	175	8-19	24	11.5	11.9	7.4	-	1

ねじ式・TS式・バット融着式 Thread · TS Socket · Butt Spigot

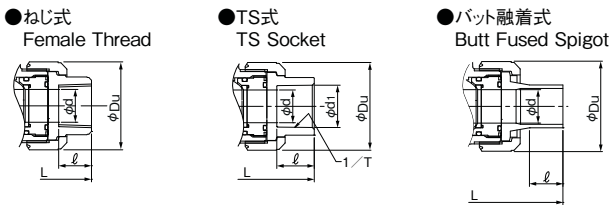

寸法表 Dimension Table

単位 Unit : mm

呼び径 Size		d	L				H	h	ℓH	Du	ℓ				d _i	1/T	重量 Weight (kg)			梱包数 Q'ty/c
A	B		ねじ Thread	TS	PVDF						ねじ Thread	融着 Butt	TS	融着 Butt			U-PVC	HT(C-PVC)	PVDF	
				ねじ Thread	融着 Butt					PVC	PVDF									
15	1/2	15	97	109	99	143	75	50	95	18	20	22	30	22.3	1/37	0.2	0.2	0.2	24	
20	3/4	20	117	132	116	152	82	53	95	18	22	25	24	26.3	1/42	0.3	0.3	0.3	24	
25	1	25	128	143	136	161	100	66	123	67	23	24	29	32.3	1/43	0.4	0.4	0.5	24	
32	1 1/4	32	146	166	148	167	115	74	123	81	23	25	32	38.4	1/37	0.6	0.6	0.6	24	
40	1 1/2	40	163	175	169	190	149	100	152	98	25	28	35	24	48.5	1/38	1.1	1.1	1.2	4
50	2	50	188	203	196	216	167	107	152	120	30	30	38	28	60.6	1/34	1.6	1.7	1.9	4
65	2 1/2	65	227	259	227	208	221	146	188	150	32	32	61	23	76.6	1/48	3.0	-	-	2
80	3	80	278	311	278	301	262	169	230	186	37	37	64	45	89.6	1/49	5.6	-	-	1
100	4	100	330	390	330	340	317	203	283	228	45	45	84	43	114.7	1/56	10.5	-	-	1

バルブ手動式 VALVES

ミニボールバルブ MINI BALL VALVE

洗淨品
Rinsed



●ホース×ホース式 (6A)
Hose×Hose (6A)

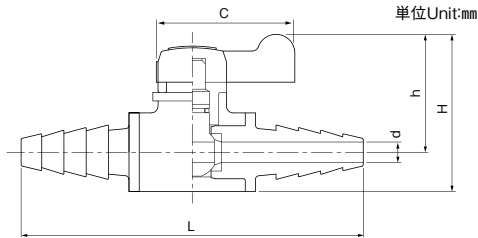

●オスねじ受口 (R 1/4・3/8)
Male Thread (R 1/4・3/8)

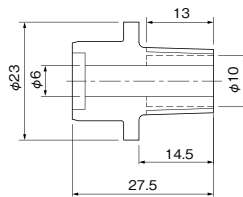

●オスねじ受口 (R 1/2)
Male Thread (R 1/2)

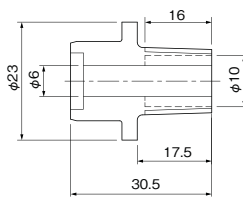

●メスねじ受口 (Rc 1/4・3/8)
Female Thread (Rc 1/4・3/8)

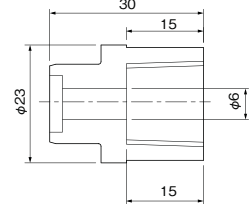

●ホース受口
Hose

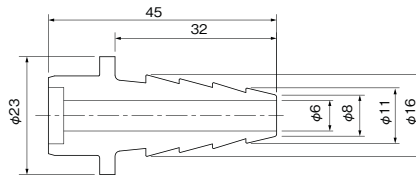

●ストレート受口
Straight

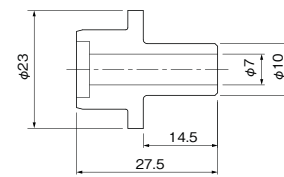

●TS式 (13A・15A)
TS Socket (13A・15A)

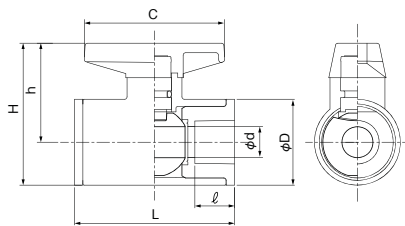

●ねじ式 (13A・15A)
Female Thread (13A・15A)

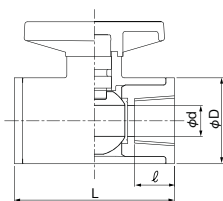

■ 寸法表 Dimension Table

単位 Unit : mm

呼び径 Size		d	H	h	D	C	ℓ		梱包数 Q'ty/c
A	B						ねじ Thread	TS	
6	1/8	6	47	35	23	40	—	—	40(20×2)
13	3/8	13	60	42	35	60	—	16.5	40
15	1/2	13	60	42	35	60	16	16.5	40

■ 受口組合せとL寸法表

L & Weight for Each Connection Type

単位 Unit : mm

呼び径 Size	接続方式 ConnectionType	L	重量 Weight(g)
6A	オスねじ × オスねじ MaleThread × MaleThread	66	30
	オスねじ × メスねじ MaleThread × FemaleThread	69	40
	オスねじ × ホース MaleThread × Hose	83	40
	オスねじ × ストレート MaleThread × Straight	66	30
	メスねじ × メスねじ FemaleThread × FemaleThread	71	40
	メスねじ × ホース FemaleThread × Hose	85	40
	メスねじ × ストレート FemaleThread × Straight	69	40
	ホース × ホース Hose × Hose	100	40
	ストレート × ストレート Straight × Straight	66	30
13A・15A	メスねじRc1/2 Female Thread Rc1/2	67	90
	TS13 TS Socket 13	67	90
	TS15 TS Socket 15	67	80

クリーンバルブ CLEAN VALVES

YPボールバルブ YP-BALL VALVE 禁油品 Oil-free

フランジ式 Flange

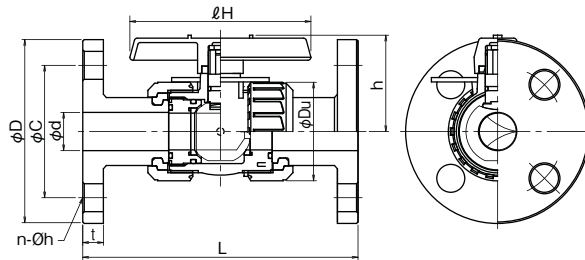

■寸法表 Dimension Table

単位 Unit : mm

呼び径 Size		d	L	h	ℓH	Du	フランジ部 Flange (JIS 10K)				重量 Weight (kg)	梱包数 Qty/c
A	B						ϕD	ϕC	n- ϕh	t		
15	1/2	15	143	50	95	49	95	70	4-15	14	0.4	12
20	3/4	20	172	53	95	59	100	75	4-15	14	0.6	12
25	1	25	187	66	123	67	125	90	4-19	14	0.9	12
32	1 1/4	30	190	74	123	81	135	100	4-19	16	1.2	12
40	1 1/2	40	212	100	152	98	140	105	4-19	16	1.7	2
50	2	50	234	107	152	120	155	120	4-19	20	2.6	2

ねじ式・TS式 Female Thread / TS Socket



●ねじ式 Female Thread

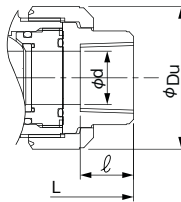

●TS式 TS Socket

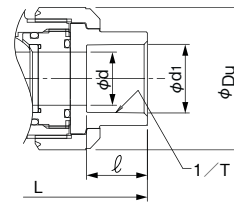

■寸法表 Dimension Table

単位 Unit : mm

呼び径 Size		d	L		h	ℓH	Du	ℓ		重量 Weight (kg)		梱包数 Qty/c
A	B		ねじ Thread	TS				ねじ Thread	TS	ねじ Thread	TS	
15	1/2	15	97	109	50	95	49	18	22	0.2	0.2	24
20	3/4	20	117	132	53	95	59	18	25	0.3	0.3	24
25	1	25	128	143	69	123	67	23	29	0.4	0.4	24
32	1 1/4	32	146	166	75	123	81	23	32	0.6	0.6	24
40	1 1/2	40	163	175	102	152	98	25	35	1.1	1.1	4
50	2	50	188	203	108	152	120	30	38	1.6	1.6	4

クリーンバルブ CLEAN VALVES

三方型ボールバルブ 3-WAY BALL VALVE 洗淨品 Rinsed

フランジ式・ねじ式・TS式 Flange Type / Thread Type / TS Socket Type

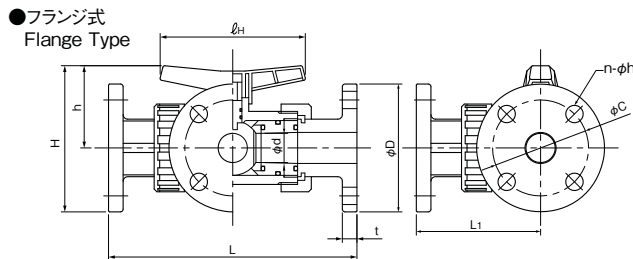

●ねじ式 Thread Type

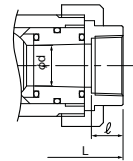

●TS式 TS Socket Type

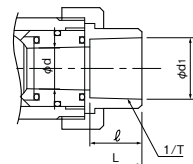

■寸法表 フランジ式 Dimension Table Flange Type

単位 Unit : mm

呼び径 Size		d	L	L1	H	h	lH	フランジ部 Flange (JIS 10K)				重量 Weight (kg)	梱包数 Q'ty/c
A	B							D	C	n-φ	t		
15	1/2	11	163	82	95	48	73	95	70	4-15	14	0.8	6
20	3/4	16	200	100	102	52	85	100	75	4-15	14	0.9	4
25	1	20	221	111	126	64	94	125	90	4-19	16	1.5	4
40	1 1/2	32	272	136	160	90	160	140	105	4-19	18	2.5	1
50	2	38	306	153	176	98	160	155	120	4-19	20	4.0	1

■寸法表 ねじ式・TS式 Dimension Table Thread Type / TS Socket Type

単位 Unit : mm

呼び径 Size		d	L		L1		H	h	lH	ねじ受口部 Female Thread		TS		重量 Weight (kg)		梱包数 Q'ty/c	
A	B		ねじ Thread	TS	ねじ Thread	TS				めねじの呼び Size	ℓ	d1	1/T テーパー Taper	ℓ	ねじ Thread		TS
15	1/2	11	118	129	59	65	73	48	73	Rc 1/2	14	22.3	1/34	24	0.3	0.3	6
20	3/4	16	134	151	67	76	81	52	85	Rc 3/4	16	26.3	1/34	28	0.4	0.4	4
25	1	20	156	175	78	88	98	64	94	Rc 1	18	32.4	1/34	32	0.6	0.6	4
40	1 1/2	32	203	232	102	116	138	90	160	Rc 1 1/2	20	48.5	1/37	41	1.5	1.5	1
50	2	38	225	260	113	130	154	98	160	Rc 2	25	60.6	1/37	47	2.2	2.3	1

ストレーナ STRAINER 洗淨品 Rinsed

フランジ式・ねじ式・TS式・ユニオン式 Flange Type / Thread Type / TS Socket Type / True Union Type



●フランジ式 Flange Type (15~50A)

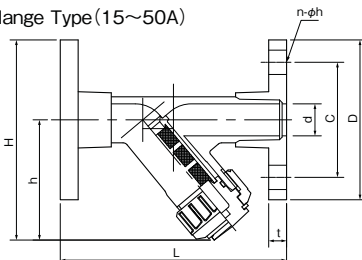

※ボネットが下向きになるように設置します。
Install strainer as bonnet bottom up.

●ねじ式 Thread Type

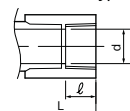

●ユニオン式 True Union Type

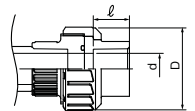

●TS式 TS Socket Type

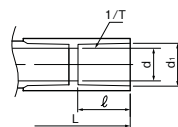

■寸法表 フランジ式 Dimension Table Flange Type

単位 Unit : mm

呼び径 Size		d	L	H	h	フランジ部 Flange (JIS 10K)				重量 Weight (kg)	梱包数 Q'ty/c
A	B					D	C	n-φ	t		
15	1/2	15	150	119	71	95	70	4-15	14	0.4	6
20	3/4	20	158	131	81	100	75	4-15	14	0.5	6
25	1	25	177	157	94	125	90	4-19	14	0.7	6
32	1 1/4	30	197	162	94	135	100	4-19	16	1.0	6
40	1 1/2	40	220	188	118	140	105	4-19	16	1.2	2
50	2	50	264	215	137	155	120	4-19	20	2.0	2
65	2 1/2	65	220	228	141	175	140	4-19	22	3.6	1
80	3	80	240	243	150	185	150	8-19	22	4.4	1
100	4	100	290	269	164	210	175	8-19	24	6.8	1

●フランジ式 Flange Type (65~100A)

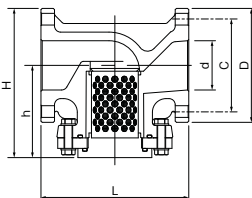

※65~100Aはフランジ式のみです。
TS, ねじ, ユニオン式はありません。
For sizes 65~100A, only flange type is available.
TS, thread and union type is not available.

■ねじ式・TS式・ユニオン式 Dimension Table Thread Type / TS Socket Type / True Union Type

単位 Unit : mm

呼び径 Size		d	L			H			h	ねじ受口部 Female Thread		TS		重量 Weight (kg)			梱包数 Q'ty/c	
A	B		ねじ Thread	TS	ユニオン True Union	ねじ Thread	TS	ユニオン True Union		めねじの呼び Size	ℓ	d1	1/T テーパー Taper	ℓ	ねじ Thread	TS		ユニオン True Union
15	1/2	15	153	190	201	86	86	96	71	Rc 1/2	16	22.4	1/34	30	0.2	0.2	0.3	6
20	3/4	20	176	210	214	99	98	111	81	Rc 3/4	19	26.5	1/34	35	0.2	0.2	0.4	6
25	1	25	200	243	254	117	114	128	94	Rc 1	22	32.6	1/34	40	0.4	0.4	0.6	6
32	1 1/4	32	232	274	287	122	117	135	94	Rc 1 1/4	26	38.6	1/34	44	0.6	0.6	0.8	6
40	1 1/2	40	271	332	301	151	147	167	118	Rc 1 1/2	31	48.7	1/34	55	0.9	0.9	1.3	2
50	2	50	321	390	370	175	172	197	137	Rc 2	38	60.8	1/34	63	1.4	1.4	2.1	2

クリーンバルブ CLEAN VALVES

バタフライバルブ BUTTERFLY VALVE

洗浄品
Rinsed

自動弁も対応することができます。
Automatic valve can be also applied.

ギヤ式 Gear Type



●40A~300A

●350A~600A

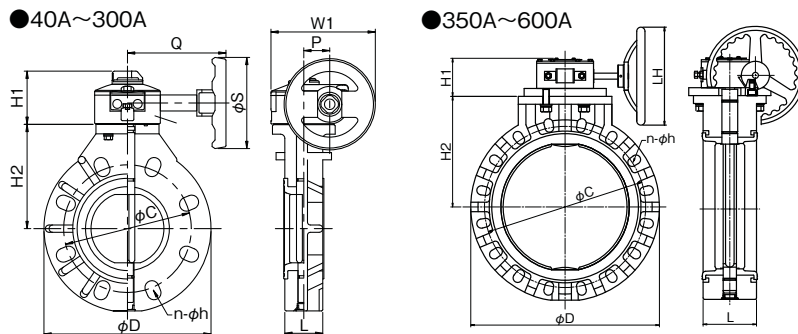

寸法表 40A~300A Dimension Table 40A~300A

単位 Unit : mm

呼び径 Size		L	D			フランジ部 Flange (JIS 10K)		H1	H2			W1	P	Q	S	重量 Weight (kg)			梱包数 Q'ty/c
A	B		PVC	PP	PVDF	C	n-φh		PVC	PP	PVDF					PVC	PP	PVDF	
40	1 1/2	33	140	138	136	105	4-19	72	105	103	102	143	36	135	125	2.1	2.0	2.2	1
50	2	43	155	152	150	120	4-19	72	112	110	109	143	36	135	125	2.3	2.1	2.5	1
65	2 1/2	46	178	174	174	140	4-19	72	123	121	119	143	36	135	125	2.7	2.5	2.9	1
80	3	46	196	192	190	150	8-19	72	130	127	126	143	36	135	125	3.0	2.8	3.3	1
100	4	52	229	225	223	175	8-19	72	152	149	147	143	36	135	125	3.8	3.6	4.2	1
125	5	56	254	249	251	210	8-23	84	169	166	164	235	68	178	210	5.9	5.4	6.6	1
150	6	60	286	280	278	240	8-23	84	178	174	173	235	68	178	210	7.5	6.8	8.5	1
200	8	71	343	336	331	290	12-23	84	230	225	223	235	68	178	210	9.3	8.4	10.9	1
250	10	78	410	402	397	355	12-25	115	250	245	243	353	88	270	350	19.3	17.8	21.9	1
300	12	114	485	477	474	400	16-25	115	280	274	272	353	88	270	350	26.4	24.5	30.8	1

注1. A部のリブはPVCのJIS10Kタイプの場合のみ設けてあります。
 注2. 呼び径40-100は約5回転、呼び径125-300は約10回転でハンドルが全開→全閉、全閉→全開となります。
 注3. ボルト穴は、JIS10K、ANSI、DINの3種類の規格に対応しています。
 Note1: Only PVC JIS10K type has centering pin A.
 Note2: Disc full-open / full close by 5 times of handle rotation for 40-100A, 10 times of handle rotation for 125-300A.
 Note3: Bolt hole is applied to JIS10K, ANSI, and DIN standards.

寸法表 350A~600A Dimension Table 350A~600A

単位 Unit : mm

呼び径 Size		L	D	H1	H2	LH	フランジ部 Flange (JIS 10K)			重量 Weight (kg)			梱包数 Q'ty/c
A	B						C	n-φh	M	U-PVC	PP	PVDF	
350	14	129	535	105	325	310	445	16-25	—	39.0	37.0	51.3	1
400	16	169	597	130	350	310	510	16-27	—	46.4	44.5	61.0	1
450	18	179	635	155	370	310	565	※20-27	M24	81.3	78.4	104.0	1
500	20	190	700	155	410	407	620	※20-27	M24	98.1	95.0	125.0	1
600	24	209	815	155	465	407	730	※24-33	M30	144.0	140.0	181.0	1

注1. 呼び径350-400は約12回転半、呼び径450-600は約16回転でハンドルが全開→全閉、全閉→全開となります。
 注2. 350、400Aのボルト穴は、JIS10K、ANSI、DINの3種類の規格に対応しています。※のうち4ヶ所はインサートとなります。
 Note1: Handle will be full-open / full close by 12.5 times for 350-400A, 16 times for 450-600A.
 Note2: Bolt holes in size 350,400A multi-conforming to JIS10K, ANSI, and DIN standards.

レバー式 Lever Type

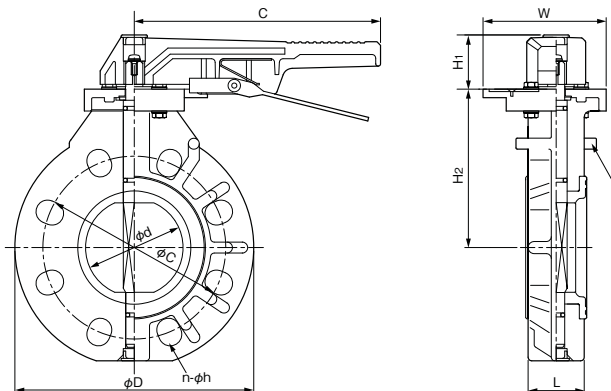

寸法表 Dimension Table

単位 Unit : mm

呼び径 Size		d	L	H1	H2	C	W	D	フランジ部 Flange (JIS 10K)		重量 Weight (kg)			梱包数 Q'ty/c
A	B								C	n-φh	U-PVC	PP	PVDF	
40	1 1/2	45	33	44	112	202	101	140	105	4-19	1.2	1.1	1.3	2
50	2	57	43	44	119	202	101	155	120	4-19	1.4	1.2	1.6	2
65	2 1/2	71	46	44	130	202	101	178	140	4-19	1.7	1.5	1.9	2
80	3	80	46	44	137	202	101	196	150	8-19	2.0	1.8	2.3	2
100	4	100	52	44	161	245	123	229	175	8-19	3.0	2.7	3.4	2
125	5	125	56	54	179	310	155	254	210	8-23	4.6	4.1	5.3	2
150	6	150	60	54	188	310	155	286	240	8-23	5.5	4.8	6.5	2
200	8	198	71	68	240	400	200	343	290	12-23	8.9	8.0	10.5	2

クリーンバルブ CLEAN VALVES

スイングチャッキバルブ CHECK VALVE SWING TYPE

洗淨品
Rinsed

フランジ式 Flange Type

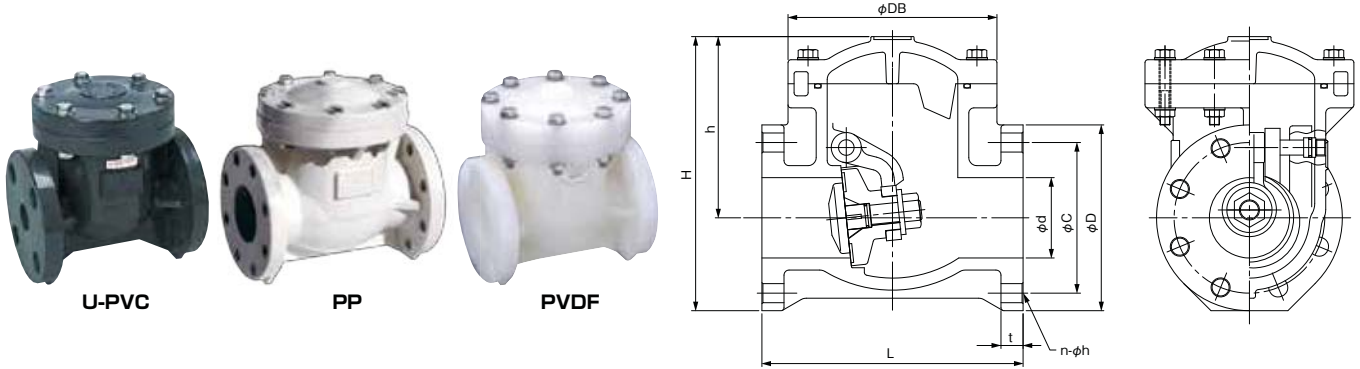

寸法表 Dimension Table

単位 Unit:mm

呼び径 Size		d	L	H	h	DB	フランジ部 Flange (JIS 10K)				重量 Weight (kg)			梱包数 Qty/c
A	B						D	C	t	n-φh	U-PVC	PP	PVDF	
15	1/2	21	140	143	93	112	100	70	14	4-15	1.0	0.8	1.3	2
20	3/4	21	140	143	93	112	100	75	14	4-15	1.0	0.8	1.3	2
25	1	25	160	180	118	132	125	90	14	4-19	1.6	1.3	2.2	2
32	1 1/4	40	180	206	136	148	140	100	18	4-19	2.7	1.9	3.3	2
40	1 1/2	40	180	206	136	148	140	105	18	4-19	2.7	1.9	3.3	2
50	2	51	200	229	152	180	155	120	20	4-19	3.6	3.0	4.5	2
65	2 1/2	67	240	254	166	200	175	140	22	4-19	4.8	3.8	6.0	2
80	3	80	260	270	178	208	185	150	22	8-19	5.8	4.3	7.5	2
100	4	100	300	318	213	265	210	175	24	8-19	9.4	7.3	11.8	1
125	5	125	350	372	247	330	250	210	24	8-23	16.4	12.7	21.0	1
150	6	150	400	420	280	375	280	240	26	8-23	20.1	16.0	26.0	1
200	8	200	500	494	329	425	330	290	30	12-23	31.7	27.0	44.0	1

注：15Aは20Aを、32Aは40Aのバルブを使用し、フランジのボルト穴をφ長穴としています。
Note: Valve 15A is same as 20A, 32A is also same as 40A, each valve is fabricated to long bolt hole of the flange.

ボールチャッキバルブ CHECK VALVE BALL TYPE

禁油品
Oil-free

ねじ式・TS式・フランジ式 TS Socket Type / Thread Type / Flange Type

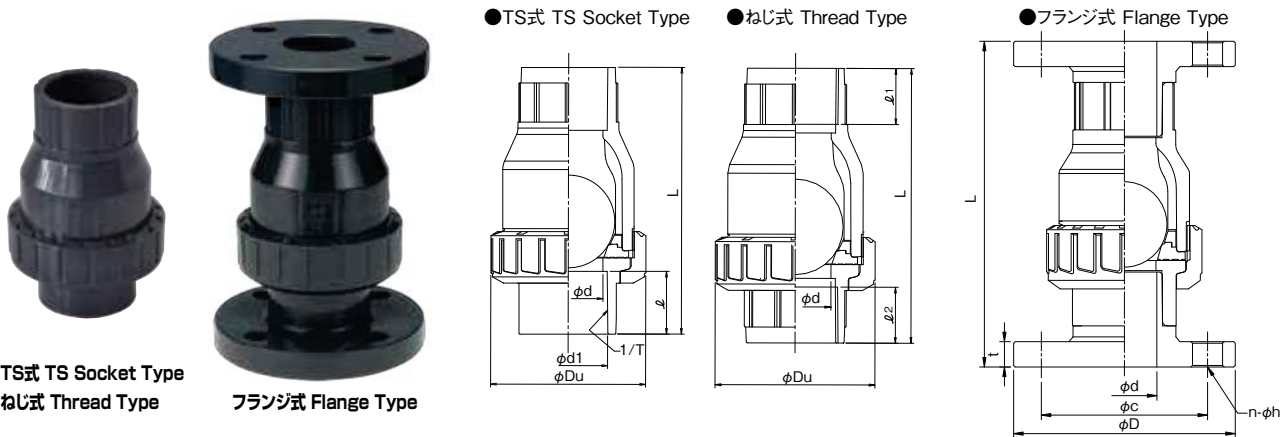

寸法表 Dimension Table

単位 Unit : mm

呼び径 Size		d	L			Du	TS				ねじ Female Thread				フランジ Flange (JIS 10K)				重量 Weight (kg)				梱包数 Qty/c	
A	B		ねじ Thread	TS	フランジ Flange		d1	1/T テーパー Taper	ℓ	めねの呼び Size	ℓ1	ℓ2	D	C	n-φh	t	U-PVC TS-φU Thread	HT (C-PVC) フランジ Flange	重量 Weight (kg) TS-φU Thread	重量 Weight (kg) フランジ Flange	重量 Weight (kg) TS-φU Thread	重量 Weight (kg) フランジ Flange	重量 Weight (kg) TS-φU Thread	重量 Weight (kg) フランジ Flange
15	1/2	16	88	98	135	49	22.3	1/37	22	Rc1/2	18	18	95	70	4-15	14	0.1	0.5	0.1	0.5	24	1		
20	3/4	20	106	118	160	59	26.3	1/42	25	Rc3/4	21	18	100	75	4-15	14	0.2	0.6	0.2	0.6	24	1		
25	1	25	112	124	170	67	32.3	1/43	29	Rc 1	24	23	125	90	4-19	14	0.3	1.0	0.3	1.0	24	1		
32	1 1/4	32	149	153	205	98	38.4	1/37	32	Rc1-1/4	30	31	135	100	4-19	16	0.6	1.6	0.6	1.6	4	1		
40	1 1/2	40	144	153	205	98	48.5	1/38	35	Rc1-1/2	31	25	140	105	4-19	16	0.5	1.6	0.5	1.6	4	1		
50	2	50	172	180	230	120	60.6	1/34	38	Rc 2	38	30	155	120	4-19	20	0.8	2.4	0.8	2.4	4	1		
65	2 1/2	65	226	259	398	150	76.6	1/48	61	Rc2-1/2	44	32	175	140	4-19	22	2.2	4.6	2.2	4.6	2	1		
80	3	78	251	281	425	150	89.6	1/49	64	Rc 3	37	37	185	150	8-19	22	2.4	5.0	2.5	5.0	2	1		
100	4	102	349	408	592	228	114.7	1/56	84	Rc 4	55	45	210	175	8-19	24	6.8	13.0	6.8	13.0	1	1		

クリーンバルブ CLEAN VALVES

ボールチャッキバルブ (ダブルユニオン) True Union CHECK VALVE BALL TYPE

禁油品 Oil-free

ねじ式・TS式・フランジ式・バット融着式 TS Socket Type / Flange Type / Thread Type / Butt Type



TS式 TS Socket Type

フランジ式 Flange Type

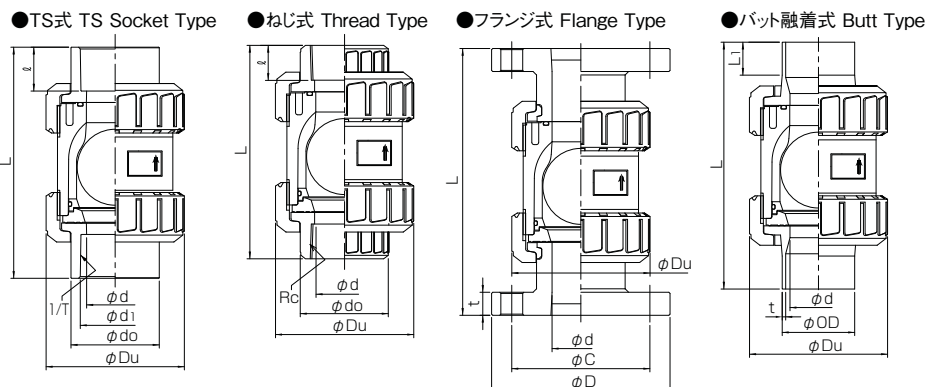

寸法表 Dimension Table

フランジ式 Flange type

単位 Unit : mm

呼び径 Size		d	L	フランジ Flange (JIS 10K)				Du	重量 Weight (kg)			
A	B			D	C	n-φh	t		U-PVC	HT	PP	PVDF
15	1/2	16	135	95	70	4-15	14	49	0.4	0.5	0.3	0.5
20	3/4	20	160	100	75	4-15	14	59	0.5	0.6	0.4	0.7
25	1	25	170	125	90	4-19	14	67	0.8	0.9	0.5	1.0
32	1 1/4	32	177	135	100	4-19	16	81	1.0	1.2	0.7	1.4
40	1 1/2	40	205	140	105	4-19	16	98	1.7	1.8	1.1	2.2
50	2	50	230	155	120	4-19	20	120	2.4	2.6	1.5	3.0

TS式・ねじ式・融着式 TS Socket Type / Thread Type / Butt Type

単位 Unit : mm

呼び径 Size		d	L			TS受口部				ねじ受口部		融着受口部		Du	重量 Weight (kg)			
A	B		TS	ねじ Thread	融着 Butt	d1	1/T	ℓ	d0	ℓ	L1	t	PVC		HT	PVDF		
15	1/2	16	101	90	92	135	22.3	1/37	22	33	18	20	30	1.9	49	0.2	0.2	0.2
20	3/4	20	121	106	105	141	26.3	1/42	25	35	18	22	24	1.9	59	0.2	0.3	0.3
25	1	25	125	112	120	143	32.3	1/43	29	44	23	24	24	2.4	67	0.3	0.4	0.5
32	1 1/4	32	153	132	134	154	38.4	1/37	32	54	23	25	25	2.4	81	0.4	0.6	0.7
40	1 1/2	40	169	158	164	184	48.5	1/38	35	66	25	28	24	3.0	98	1.1	1.2	1.5
50	2	50	200	186	194	213	60.6	1/34	38	77	30	30	28	3.0	120	1.4	1.7	1.9

リフトチャッキバルブ CHECK VALVE LIFT TYPE

洗浄品 Rinsed

フランジ式 Flange Type



寸法表 Dimension Table

単位 Unit: mm

呼び径 Size		d	L	H	h	フランジ部 Flange (JIS 10K)				重量 Weight (kg)	梱包数 Q'ty/c
A	B					D	C	n-φh	t		
15	1/2	15	130	119	71	95	70	4-15	14	0.4	6
20	3/4	20	150	131	81	100	75	4-15	14	0.5	6
25	1	25	160	157	94	125	90	4-19	14	0.8	6
32	1 1/4	32	180	162	94	135	100	4-19	16	1.0	6
40	1 1/2	40	200	188	118	140	105	4-19	16	1.4	2
50	2	50	234	215	137	155	120	4-19	20	2.2	2

注.ねじ受口、TS受口、ユニオン受口も受注生産いたします。
Thread, TS and union type available.

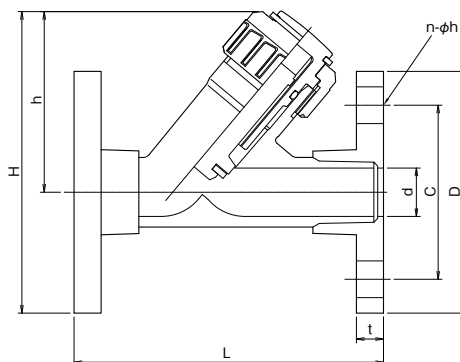

※ボンネットが上向きになるように設置します。
Install the valve as bonnet upward.

クリーンバルブ CLEAN VALVES

リリーフバルブ RELIEF VALVE

洗淨品
Rinsed

フランジ式・ねじ式・TS式

Flange Type / Thread Type / TS Socket Type



Type 712

●フランジ式 Flange Type

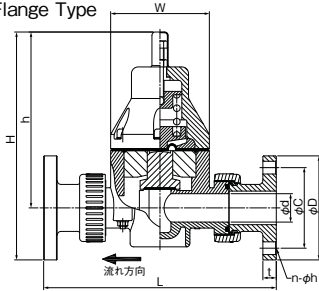

●ねじ式 Thread Type

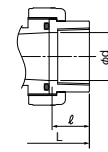

●TS式 TS Socket Type

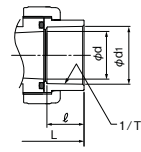

寸法表 フランジ式 Dimension Table Flange Type

単位 Unit: mm

呼び径 Size		d	L	H			h	W	固定用ねじ(2カ所) Thread		フランジ部 Flange (JIS 10K)					重量 Weight(kg)			梱包数 Q'ty/c
A	B			PVC	PP,PVDF				F	Mxe	D		C	n-φh	t	PVC	PP	PVDF	
15	1/2	15	224	222	220	174	81	40	M6×16	95	92	70	4-15	14	1.2	0.9	1.5	1	
20	3/4	20	255	252	250	202	107	46	M6×16	100	97	75	4-15	14	1.3	1.8	1.6	1	
25	1	26	269	265	263	202	107	46	M6×16	125	122	90	4-19	14	2.5	2.0	2.9	1	
32	1 1/4	32	323	330	328	262	147	65	M8×16	135	132	100	4-19	16	5.8	4.6	6.4	1	
40	1 1/2	40	338	332	330	262	147	65	M8×16	140	137	105	4-19	16	6.0	4.7	6.6	1	
50	2	50	346	340	338	262	147	65	M8×16	155	152	120	4-19	20	6.4	5.1	7.1	1	

ねじ式・TS式 Dimension Table Thread Type / TS Socket Type

単位 Unit: mm

呼び径 Size		d	L		H	h	W	固定用ねじ(2カ所) Thread		ねじ受口部 Female Thread		TS			重量 Weight(kg)		梱包数 Q'ty/c
A	B		ねじ Thread	TS				F	Mxe	めねじの呼び Size	ℓ	d1	1/Tテーパ Taper	ℓ	PVC	PVDF	
13	3/8	10	158	172	197	172	81	40	M6×16	Rp 3/8	15	18.3	1/31	19	0.9	1.1	1
15	1/2	15	161	174	197	172	81	40	M6×16	Rp 1/2	17	22.3	1/37	22	1.0	1.2	1
20	3/4	21	195	213	240	202	107	46	M6×16	Rp 3/4	18	26.3	1/42	25	2.0	2.2	1
25	1	26	201	220	240	202	107	46	M6×16	Rp 1	18	32.3	1/43	29	2.0	2.3	1
32	1 1/4	33	267	278	320	262	147	65	M8×16	Rp 1 1/4	23	38.4	1/37	32	5.1	5.6	1
40	1 1/2	40	277	284	320	262	147	65	M8×16	Rp 1 1/2	23	48.5	1/38	35	5.2	5.7	1
50	2	50	292	293	320	262	147	65	M8×16	Rp 2	28	60.6	1/34	38	5.3	5.8	1

注. 本体材質により寸法値は多少異なります。
Each dimension might differ from the dimension table depending on body material.

定圧弁 PRESSURE REGULATION VALVE

洗淨品
Rinsed

フランジ式・ねじ式・TS式

Flange Type / Thread Type / TS Socket Type



●フランジ式 Flange Type

※標準仕様 Standard Type

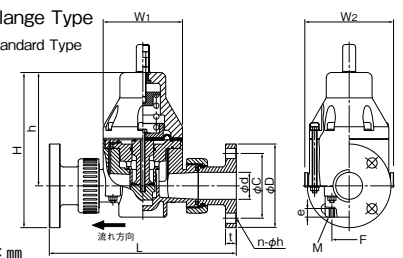

寸法表 フランジ式 Dimension Table Flange Type

単位 Unit: mm

呼び径 Size		d	L	H	h	W1	W2	W3	固定用ねじ(2カ所) Thread		フランジ部 Flange (JIS 10K)					重量 Weight(kg)			梱包数 Q'ty/c
A	B								F	Mxe	D	PCD	n-φh	t	PVC	PP	PVDF		
15	1/2	15	224	220	172	81	97	124	41	M6×16	95	70	4-15	14	1.3	1.0	1.5	1	
20	3/4	20	255	252	202	107	123	150	47	M6×16	100	75	4-15	14	2.3	1.9	2.6	1	
25	1	26	269	265	202	107	123	150	47	M6×16	125	90	4-19	14	2.6	2.1	2.8	1	
32	1 1/4	32	323	330	262	147	163	190	66	M8×16	135	100	4-19	16	5.8	4.7	6.4	1	
40	1 1/2	40	338	332	262	147	163	190	66	M8×16	140	105	4-19	16	6.0	4.8	6.6	1	
50	2	50	346	340	262	147	163	190	66	M8×16	155	120	4-19	20	6.4	5.1	7.1	1	

※圧力ゲージ付き
With Pressure Gauge

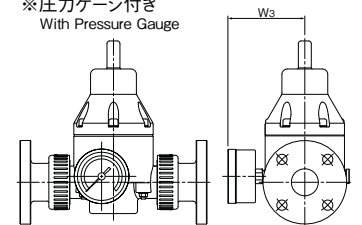

ねじ式・TS式 Dimension Table Thread Type / TS Socket Type

単位 Unit: mm

呼び径 Size		d	L			H	h	W1	W2	W3	固定用ねじ(2カ所) Thread		ねじ受口部 Female Thread		TS			重量 Weight(kg)		梱包数 Q'ty/c
A	B		ねじ Thread	融着 Butt	TS						F	Mxe	めねじの呼び Size	ℓ	d1	1/Tテーパ Taper	ℓ	PVC ねじ	PVDF ねじ	
13	3/8	10	158	172	-	197	172	81	97	124	41	M6×16	Rp 1/4	45	18.3	1/31	19	0.9	0.9	1
15	1/2	16	161	174	227	197	172	81	97	124	41	M6×16	Rp 1/2	17	22.3	1/37	22	1.0	1.0	1
20	3/4	20	195	213	263	240	202	107	123	150	47	M6×16	Rp 3/4	18	26.3	1/42	25	2.0	2.0	1
25	1	25	201	220	269	240	202	107	123	150	47	M6×16	Rp 1	18	32.3	1/43	29	2.0	2.0	1
32	1 1/4	32	267	278	330	320	262	147	163	190	66	M8×16	Rp 1 1/4	23	38.4	1/37	32	5.1	5.1	1
40	1 1/2	41	277	284	336	320	262	147	163	190	66	M8×16	Rp 1 1/2	23	48.5	1/38	35	5.2	5.2	1
50	2	52	292	293	342	320	262	147	163	190	66	M8×16	Rp 2	28	60.6	1/34	38	5.3	5.3	1

●ねじ式 Thread Type

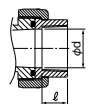

●TS式 TS Socket Type

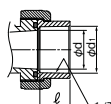

注. 本体材質により寸法値は多少異なります。
Each dimension might differ from the dimension table depending on body material.

自動式バルブ AUTOMATIC VALVES

エア式自動バルブ Pneumatic Operation Valves



エア式ダイヤフラムバルブF型
Pneumatic Diaphragm Valve F-Type

本体材質 Body	呼び径 Size	フランジ式 Flange	ねじ式 Thread	TS式/融着式* TS/Butt
U-PVC	15A~100A	○	○	○
HT(C-PVC)	15A~100A	○	—	○
PP	15A~100A	○	—	—
PVDF	15A~100A	○	○	○



エア式ボールバルブS型
Pneumatic Ball Valve S-Type

本体材質 Body	呼び径 Size	フランジ式 Flange	ねじ式 Thread	TS式/融着式* TS/Butt
U-PVC	15A~100A	○	○	○
HT(C-PVC)	15A~100A	○	—	○
PP	15A~100A	○	—	—
PVDF	15A~100A	○	○	○



エア式S型バタフライバルブ
Pneumatic S-Type Butterfly Valve

本体材質 Body	呼び径 Size	作動方式 Operation Type
U-PVC	40A~400A	復作動 Double 正・逆作動 Single
PP	40A~400A	復作動 Double 正・逆作動 Single
PVDF	40A~400A	復作動 Double 正・逆作動 Single



エアオペレーションバルブ
Air Operation Valve

本体材質 Body	呼び径 Size	TS式 TS
U-PVC	15~65A	○

ボールバルブ互換タイプユニオン継手とは互換性ありませんのでご注意ください。
Incompatible with True Union Fitting which is compatible with Ball Valve.

電動式自動バルブ Electric Operation Valves



電動式ダイヤフラムバルブKS型
Electric Diaphragm Valve KS-Type

本体材質 Body	呼び径 Size	フランジ式 Flange	ねじ式 Thread	TS式 TS
U-PVC	15A~50A 65A~150A	○	○	○
HT(C-PVC)	15A~50A 65A~100A	○	○	○
PP	15A~150A	○	—	—
PVDF	15A~100A	○	—	—



電動式ボールバルブK型
Electric Ball Valve K-Type

本体材質 Body	呼び径 Size	フランジ式 Flange	ねじ式 Thread	TS式/融着式* TS/Butt
U-PVC	15A~100A	○	○	○
HT(C-PVC)	15A~100A	○	—	○
PP	15A~100A	○	—	—
PVDF	15A~100A	○	○	○



電動式ボールバルブN型
Electric Ball Valve N-Type

本体材質 Body	呼び径 Size	フランジ式 Flange	ねじ式 Thread	TS式 TS
U-PVC	15A~100A	○	○	○
HT(C-PVC)	15A~100A	○	—	○
PP	15A~100A	○	—	—
PVDF	15A~100A	○	○	○



電動式YPボールバルブ
Electric YP-Ball Valve

本体材質 Body	呼び径 Size	フランジ式 Flange	ねじ式 Thread	TS式 TS
U-PVC	15A~50A	○	○	○



電動式三方型ボールバルブ
Electric 3-Way Ball Valve

本体材質 Body	呼び径 Size	フランジ式 Flange	ねじ式 Thread	TS式 TS
U-PVC	15A~50A	○	○	○



電動式バタフライバルブK型
Electric Butterfly Valve K-Type

本体材質 Body	呼び径 Size	フランジ式 Flange
U-PVC	40A~300A	○
PP	40A~300A	○
PVDF	40A~300A	○



電動式バタフライバルブN型
Electric Butterfly Valve N-type

本体材質 Body	呼び径 Size	フランジ式 Flange
U-PVC	40A~300A	○
PP	40A~300A	○
PVDF	40A~300A	○

※バルブ自動式の詳細は別紙「エスロンバルブ総合カタログ」をご覧ください。 Please refer to brochure "Eslon Valves Catalogue" for details of automatic operation valves.

※融着式はPVDFのみ only pvdf

クリーンパイプ

PVDF-UHPパイプ

クリーンバルブ

技術データ

施工

技術データ集 TECHNICAL DATA

基本物性 BASIC PROPERTIES

表中に記載された性能は参考情報であり、その性能を保証するものではありません。
The properties are for reference purpose only and are not guaranteed.

項目 Properties	単位 Unit	試験方法 Test Standard	エスロンスーパークリーン Eslon Super Clean	HTエスロクリーン HT EslonClean	PVDF-UHP	
物理的 Physical	比重 Specific Gravity	g/cc	ASTM D792	1.41	1.48	1.78
	硬度 Rockwell Hardness	—	ASTM D785	110~120	140	110
	吸水率 Water Absorption	%	ASTM D570	0.01~0.03	0.04~0.06	< 0.04
機械的 Mechanical	引張強さ Tensile Strength at Yield	MPa	ASTM D638	49	53	50
	破断伸び Tensile Elongation at Break	%	ASTM D638	150~250	50~100	20~50
	曲げ強さ Flexural Strength	MPa	ASTM D790	90~100	88	69
	圧縮強さ Compression Strength	MPa	ASTM D695	70~80	69	60
	縦弾性率 Modulus of Elasticity	MPa	ASTM D790	2700	2900	2200
	ポアソン比 Poisson's Ratio	—	—	0.38	0.38	0.28
	シャルピー衝撃強さ Charpy Impact Strength	KJ/m ²	JIS K 7111	21	> 7	—
熱的 Thermal	線膨張係数 Linear Expansion Coefficient	1/°C	ASTM D696	7×10 ⁻⁵	7×10 ⁻⁵	12~14×10 ⁻⁵
	比熱 Specific Heat	KJ/kg·K	ASTM C177	1.2	0.84~1.2	1.2~1.6
	熱伝導率 Thermal Conductivity	W/m·K	ASTM C177	0.15	0.11~0.14	0.20
	ピカット軟化温度 Vicat Soften Temperature	°C	JIS K 7206	81	113	170
	燃焼性 Flammability	—	ASTM D3801	判定 [V-0相当]	判定 [V-0相当]	判定 [V-0相当]
電氣的 Electrical	体積固有抵抗 Volume Resistivity	Ω·cm	ASTM D257	> 1×10 ¹⁵	> 1×10 ¹⁵	> 1×10 ¹⁴
	耐電性 Dielectric Strength	KV/mm	ASTM D149	> 40	> 40	> 40

溶出性能 ELUTION PERFORMANCE

1.パイプ Pipe

検出項目 Detection Item	エスロンスーパークリーン Eslon Super Clean		PVDF-UHP		PP-HP	
	封入水濃度 Concentration (μg/l)	溶出速度 Elution Speed (μg/m ² ·day)	封入水濃度 Concentration (μg/l)	溶出速度 Elution Speed (μg/m ² ·day)	封入水濃度 Concentration (μg/l)	溶出速度 Elution Speed (μg/m ² ·day)
TOC	20.0	5.0	8.0	3.0	14.0	4.0
SiO ₂	<2.0	<0.59	<2.0	<0.64	2.7	0.83
Na	0.01	0.003	<0.01	<0.003	1.2	0.37
K	0.01	0.003	<0.01	<0.003	0.06	0.02
Ca	0.23	0.06	1.1	0.35	0.07	0.02
Fe	0.07	0.02	0.05	0.02	0.07	0.02
Cu	<0.01	<0.003	<0.005	<0.002	<0.005	<0.002
Al	0.17	0.05	0.08	0.03	1.2	0.37

- テスト方法は、半導体基盤技術研究会提唱の封水験法による。
Test method: The elution test method proposed by the Semiconductor Basic Technology Research Association.
- テスト期間は8~30日間。
The tested period is 8 to 30 days.

2.バルブ Valves

単位 Unit: μg/l

バルブ Valves	シール材 Sealing	15日間 After 15 Days						30日間 After 30 Days					
		TOC	Pb	Ca	Zn	Cd	Sn	TOC	Pb	Ca	Zn	Cd	Sn
U-PVC ボールバルブ U-PVC Ball Valve	EPDM	1.3	ND	35	25	ND	ND	2.4	ND	30	220	ND	ND
U-PVC ダイアフラムバルブ U-PVC Diaphragm Valve	PTFE	0.6	ND	60	15	ND	ND	0.6	ND	70	50	ND	ND

技術データ集 TECHNICAL DATA

エスロンバルブの開度と流量の関係 FLOW CHARACTERISTICS OF ESLON VALVES

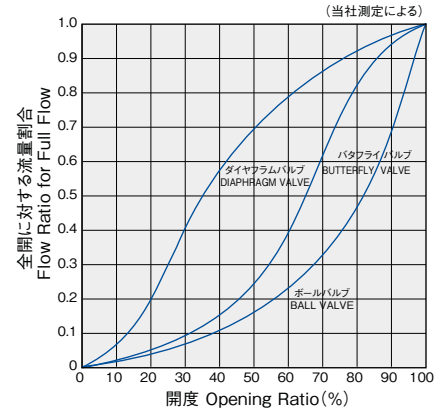

エスロンバルブのCv値 Cv Value of ESLON VALVES

Cv値 (valve constant) とは、米国で使用されているバルブの容量係数で、全開状態にしたバルブ前後の差圧が1psi (0.0703kg/cm²) のとき、60°F (15.5°C) の清水が1分間に何ガロン (米ガロン=3.7852ℓ) そのバルブを通過するかを表した無次元の数値で、1ガロンをCv値1としています。

Cv value (valve constant) is the flow coefficient used in USA, and non-dimensional value representing how many gallons (1 US gallon = 3.7852 litres) of water of 60°F (15.5°C) pass valve for one minute, where the pressure difference at the inlet and the outlet of the valve is 1 psi (0.0703kgf/cm²) at its full open. 1 gallon is treated as 1Cv.

$$Cv = Q \sqrt{\frac{\gamma}{P_1 - P_2}}$$

- Cv: バルブの容量係数 Valve capacity coefficient
- Q: 体積流量 Volmetric flow [gal/min]
- P₁: 上流側圧力 Inlet pressure [psi]
- P₂: 下流側圧力 Outlet pressure [psi]
- γ: 比重 Specific gravity

Cv値 Cv Value

品名 Valves	呼び径 Size	15	20	25	32	40	50	65	80	100	125	150	200	250	300	350	400	450	500	600
ダイヤフラムバルブ Diaphragm Valve		5.7	12	17.6	17.6	28	43.5	122	126	268	303	414	707	1177	—	—	—	—	—	—
分岐ダイヤ(分岐側) Dead Space Free Tee-Type Diaphragm Valve		5.2	—	13.1	—	30.1	—	—	—	—	—	—	—	—	—	—	—	—	—	—
ボールバルブ Ball Valve		12.1	31.5	48.9	80.1	154	267	352	471	780	—	—	—	—	—	—	—	—	—	—
バタフライバルブ Butterfly Valve		—	—	—	—	74	172	282	309	446	755	993	2213	3440	4929	6311	8757	11107	14622	17945
チャッキバルブ Check Valve	スイング式 Swing Type	—	17.6	24.2	—	67.8	91.4	222	306	596	771	1084	1920	—	—	—	—	—	—	—
	ボール式 Ball Type	10.5	25.7	36.9	71	84	146	235	280	547	—	—	—	—	—	—	—	—	—	—
	リフト式 Lift Type	5.6	8.3	13.8	20.2	31.7	56.5	—	—	—	—	—	—	—	—	—	—	—	—	—
ストレーナ Strainer		2.8	4.9	7.2	13.2	17.9	28.7	39.8	52.6	84.6	—	—	—	—	—	—	—	—	—	—
リリーフバルブ Relief Valve		2.46	7.2	7.58	19.4	21.3	21.3	—	—	—	—	—	—	—	—	—	—	—	—	—

エスロンバルブの流量線図 FLOW DIAGRAMS FOR ESLON VALVES

ダイヤフラムバルブ Diaphragm Valve

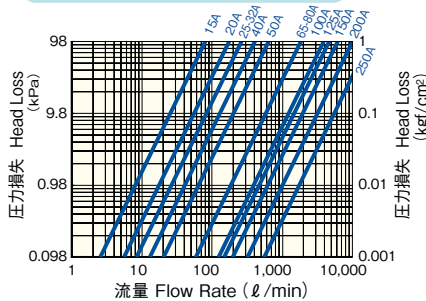

分岐ダイヤフラムバルブ Dead Space Free Tee-Type Diaphragm Valve

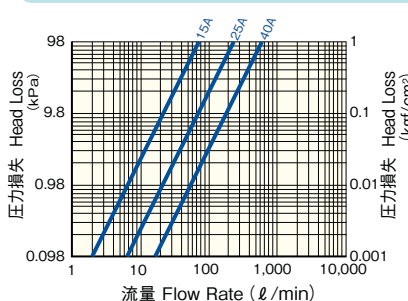

ボールバルブ Ball Valve

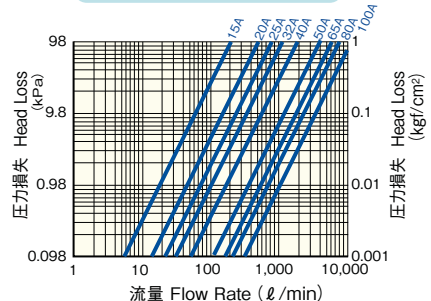

バタフライバルブ Butterfly Valve

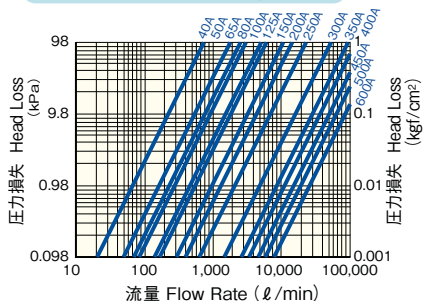

スイングチャッキバルブ Swing Check Valve

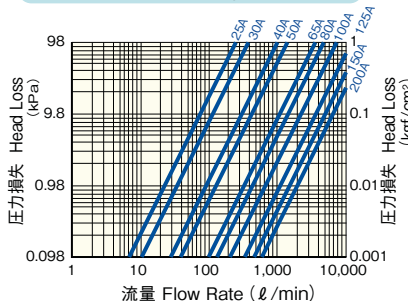

ボールチャッキバルブ Ball Check Valve
フットバルブ Foot Valve

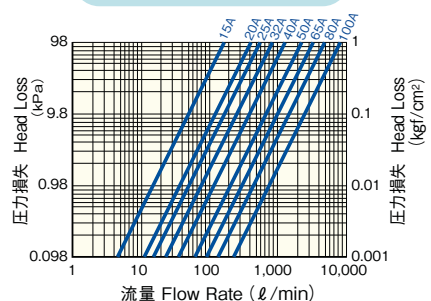

施工 INSTALLATION

安全上の注意 Understanding Safety Alert Messages

安全かつ適切に使用していただくために、必ずお守りいただくことを説明しています。表示と意味は以下の通りです。
 There are several types of safety-alert messages which appear throughout this Technical Manual. Familiarize yourself with these types of messages and the importance of the various signal words, as explained below.

- ⚠ この表示を無視して誤った取り扱いをすると、使用者が死亡、または重傷を負う危険性が想定される内容が記載されています。
 Indicates a potentially hazardous situation which, if not avoided, will result in death or serious injury.
- ❗ この表示を無視して取り扱いをすると、使用者が障害を負う危険性が想定される内容及び物的損害の発生が想定される内容が記載されています。
 Indicates a potentially hazardous situation which, if not avoided, may result in minor or moderate injury.

取扱い、保管 Handling and Storage

■取扱い Handling

- ❗ 管、継手、バルブ類は落下させたり、放り投げたり、治工具でたたいたりしないでください。破損することがあります。
 Pipes, Fittings and valves require more care in handling so as not to be dropped, threw or tapped to avoid damages.
- ⚠ バルブの作動確認をする場合は、指・手・足をバルブ内に絶対に入れないでください。バルブの開閉により、指・手・足の切断など重傷を負うおそれがあります。
 Do not insert your hands into the valve in operating test to prevent serious injury accident.

■保管 Storage

- ❗ 管材は屋内に保管してください。やむを得ず屋外に保管する時は遮光シートなどで覆い、直射日光から保護してください。遮光シートは高反射のシルバーシートを推奨します。
 If possible, pipe should be stored inside. When this is no possible, the pipe should be protected from the sun with shading sheet. The best type of shading sheet is silver colored sheet with highly reflective performance.
- ❗ パイプはラックに保管する場合、平坦な敷板上に置くか、サポート間隔を900mm以内としてください。地面上に保管する場合は、平坦な地面にサポート間隔を900mm以内に枕木を敷いて上に保管してください。いずれの場合も、出来るだけ梱包状態で保管し、最大積載段数は3段としてください。
 If the pipe is stored in racks, it should be continuously supported along its length or the spacing supports should not exceed 900 mm.
 If the pipe is stored on ground, it should be stored on square lumbers where should not exceed 900 mm.
 If possible, the pipe should be stored in its original packaging. It should be stacked up to maximum 3 layers.

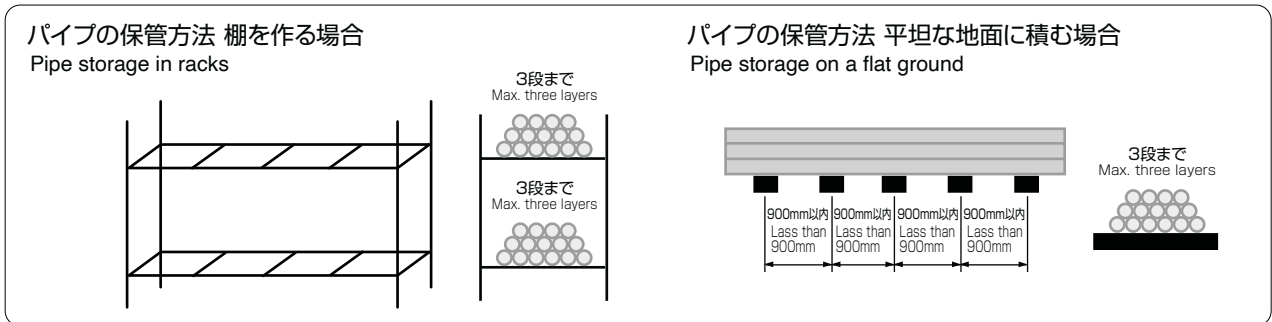

- ❗ クリーンパイプ、継手、バルブは埃などのコンタミを防止するため包装しています。施工時に必要となるまで取り外さないでください。
 Esilon clean pipes are closed with pipe end caps and fittings & valves are packaging in polyethylene bag.
 Do not take them off for before the installation to prevent dust from contamination.

接着接合 Solvent Cement Joining

接着接合の基本作業は、詳細に説明した「クリーン施工要領書」を別途ご用意しておりますのでご参照ください。
 For details, refer to the instruction manual for solvent cement joining.

1. 管の切断 Cut Pipe Square

管軸に対して直角に切断します。
 Cut the pipe at a right angle to the axis.

2. 管の内外面の面取り Deburr

管の内面・外面のバリ取りを行ってください。200A以上の管は図のように管外面の面取りを行ってください。
 Remove all burrs inside and outside at the end of pipe.
 The end of pipe must be chamfered as shown figure at right for large size pipe as 200A and over.

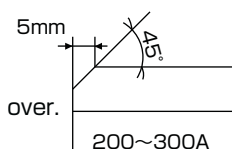

3. 管・継手接合面の清掃 Clean Joint Components

接着接合面となる管外面と継手内面を乾いたウエスで土、ほこり、水分、油分をふき取ってください。
 Wipe away all loose dirt and moisture from pipe outside and fitting inside with clean and dry rag.

施工 INSTALLATION

4. 管・継手の適合確認 Check Joint Interference Fit

管を継手に真っ直ぐに軽く挿入して、管が受口長さの1/3~2/3に止まるか確認してください。
管が入り難かったり、奥まで入る時は継手を換えてください。

To check, lightly insert pipe into fitting socket. For proper interference fit, fitting should go over end of pipe easily but become tight about 1/3 to 2/3 of the way on.
If it can not become proper interference fit, change new fitting.

5. 標線の記入 Depth of Entry Mark

管の挿入確認のため、継手受口の長さを測り、管に受口長さの標線を記入します。

Marking the depth of entry is a way to check if pipe has reached the bottom of fitting socket.

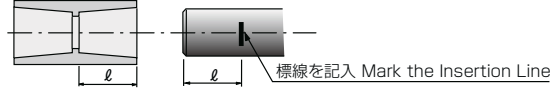

6. 挿入治工具の取付け Assemble Insertion Tools for Large size pipes

大口径では挿入力が大きいので、管と継手に挿入治工具(レバブロックとワイヤ)を取付けます。
Set insertion tools as lever-block and wires for fitting and pipe for large size pipe.

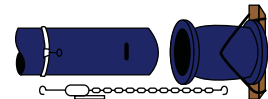

7. 接着剤の塗布 Apply Solvent Cement

刷毛を用いて継手受口と管外面の両方に適量の接着剤を素早く塗布します。

継手受口をやや少なめにし、管外面をやや多めに接着剤を塗布し、接着剤が管内にはみ出さないように注意してください。

Using brush, solvent cement must be applied uniformly to both fitting socket and pipe outside as soon as possible. It must be careful not to flow out inside the pipe. Therefore, apply little less cement to fitting socket than pipe outside.

継手側：心持ち少な目に
Fitting : A little less adhesive



管側：やや多目に
Pipe : A little more adhesive

8. 管の挿入と保持 Joint Assembly and Hold

接着剤が乾燥しない内に管と継手をセットした後、管を標線まで真っ直ぐに一気に挿入してください。
管が戻るのを、下表のとおり挿入したまま保持してください。

Without delay, while cement is still wet, assemble the pipe and fitting, and then insert immediately the pipe into fitting socket until the mark of entry.

To avoid pipe push out, hold the pipe and fitting together for proper time as shown right table.

接合後、接着剤の揮発物を放出するため、配管は換気できるよう開放してください。

Piping after jointing, must be ventilated to emit solvent vapors. Do not close the ends of piping.

9. 養生 Initial Set Time and Cure Time

接合した継手は接着剤が固まるまで動かさないでください。また、接合後水圧をかけるには適切な養生時間が必要です。
それぞれの時間は下表のとおりです。

Handle newly assembled joints carefully until initial set has taken place. The joint must adequately cure prior to use pressure application as shown below table.

推奨接着剤

Recommended Eslon Solvent Cement

品名 Grade	エスロン スーパークリーンパイプ Eslon Super Clean Pipe			HT エスロクリーンパイプ HT EsloClean Pipe		
	13~300A	No.90C/ No.90Cホワイト	150~600A	No.95C/ No.95Cホワイト	No.100S	
		1kg 500g		1kg		1kg 500g 250g

※刷毛は付いておりません
Blush is not included

挿入保持時間、養生時間

Average Insert Hold Time and Cure Time

作業温度 Temperature	5~15℃			15~35℃		
	サイズ Pipe Size	13~75(80)	100~200	250~300	13~75(80)	100~200
挿入保持時間 Insert Hold Time	2分(min)	3分(min)	4分(min)	1分(min)	1分(min)	2分(min)
養生時間 Cure Time	24時間(hrs)	48時間(hrs)	48時間(hrs)	12時間(hrs)	24時間(hrs)	24時間(hrs)

※接着剤は有機溶剤を含む可燃性危険物です。火災・爆発事故を防止するため、保管場や作業場では煙草・トーチ・火花等火気厳禁です。

また、換気を十分に行って作業してください。揮発物は人体に悪影響を及ぼすことがあります。

Solvent cement is flammable hazardous material including organic solvents.

To avoid explosion and any serious incidents, prohibit use of fire such as smoking, torching, or fire-working around work and storage area. Ventilate sufficiently, do not inhale solvent vapors.

施工 INSTALLATION

融着接合 Socket Fusion Joining

接着接合の基本作業は、詳細に説明した「クリーン施工要領書」を別途ご用意しておりますのでご参照ください。
For details, refer to the instruction manual for welding machine.

1. 融着機 Socket Fusion Machine

■N75型 Type N75
 手動操作、適用サイズ:13~75(80A)
 Manual Operation, Size Range: 13~75(80A)
 電圧:単相AC100V
 Voltage:Single-phase AC100V
 電源容量:1.5Kw
 Power supply capacity:1.5Kw
 電流:15A
 Electric current:15A

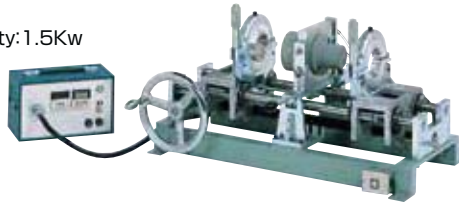

■150型 Type 150
 半自動操作、適用サイズ:65~200A
 Semi-Automatic Operation,
 Size Range 65~200A
 電圧:三相AC200V
 Voltage:Three-phase AC200V
 電源容量:2Kw
 Power supply capacity:2Kw
 電流:20A
 Electric current:20A

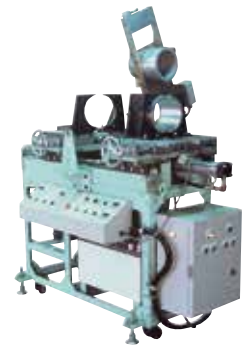

2. 融着接合手順 Fusion Joining Process

150型を用いたソケット融着の例 A Example of Socket Fusion Joining with Using Type 150 Machine

1. 管の切断 Cut Pipe Square

管の切断は、軸に標線を入れて直角に手鋸などで切断してください。
 Pipe must be cut as square as possible by proper hand saw or mechanical saw.

2. 管の内外面の面取り Deburr

管の内外面のバリ取りを行ってください。
 Remove all burrs inside and outside at the end of pipe.

3. 管・継手接合面の清掃 Clean Joint Components

接着接合面となる管外面と継手内面を乾いたウエスで土、ほこり、水分、油分をふき取ってください。
 Wipe away all loose dirt and moisture from pipe outside and fitting inside with clean and dry rag.

4. ヒーターフェイスの取付け Setting Heater Face



5. 管と継手のクランプ取付け Setting Each Clamp for Pipe & Fitting

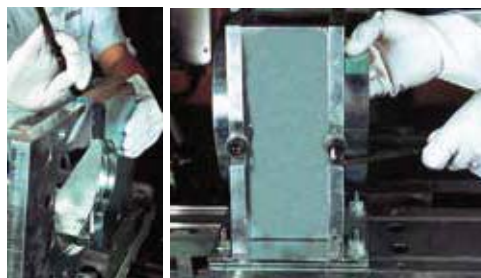

6. 管と継手のセット Clamping Pipe and Fitting



7. 管と継手の芯合せ確認と調整 Checking and Adjusting Alignment Pipe & Fitting



8. 管・継手とヒーターフェイスの芯合せと調整 Checking and Adjusting Alignment Heater Face for Pipe & Fitting

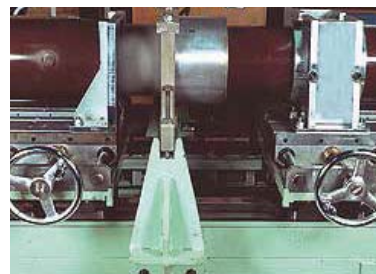

9. ヒーターフェイスの温度確認 Checking Temperature of Heater Face



施工 INSTALLATION

10. 溶融時間の設定 Setting Melting Time



11. 管・継手のヒーターフェイスへの挿入 Inserting Pipe & Fitting to Heater Face



12. 融着工程の自動運転 Automatic Operation for Fusion Process

下図に示す手順が自動運転で行われ、接合が完了します。

Fusion processes are carried out automatically as shown below flow chart.

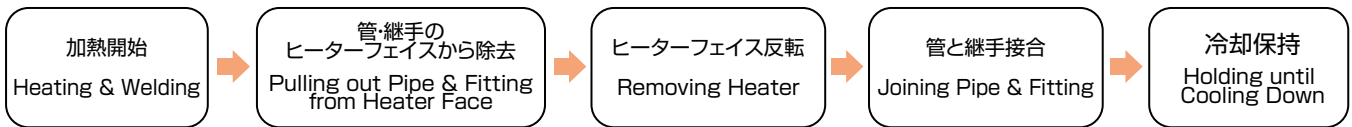

融着施工の詳細については、「エスロンクリーン管材施工要領書」を参照ください。
Please refer to "Eslon Clean Piping Installation Manual" for details of socket fusion joining.



融着機の操作運転中は、機械やヒーターに体や顔を近づけたりしないでください。特に、150型の自動運転中はヒーターや油圧シリンダーが作動するので非常に危険です。
During operating fusion machine, do not allow the any part of your body or face stick out toward the the fusion machine and Heater. It is dangerous, because the heater plate and the hydraulic cylinders of type 150 fusion machine becomes active automatically.



融着機の電源電圧は、AC100V、AC200V仕様となっています。標準以外の電源電圧でご使用される場合、変圧器が必要となりますので、ご準備ください。

The power supply voltage of the fusion machine is AC100V, AC200V specification. If you use a power supply voltage other than the standard, a transformer is required, so please prepare it.



感電防止のため、融着機にはアースを取ってください。
Be sure to connect the ground wire to prevent electric shock.

■重要な注意事項 Important Caution



接着剤、アセトン（融着施工時）は有機溶剤を含む可燃性危険物です。火災、爆発事故を防止するため、保管場や作業場では煙草、トーチ、火花等火気厳禁です。また、換気を十分行って作業してください。揮発物は人体に悪影響を及ぼすことがあります。
Acetone for cleaning and solvent cements for pipe and fitting are flammable. To avoid fire and explosion accidents, extinguish all smoking material, flame, or other ignition sources in working or storage areas. Be sure to work only in a well ventilated space. Ingestion or intentional inhalation of solvent vapors can be harmful or fatal.



接着剤の溶剤が揮発しにくいいため、気温が5℃以下での接合作業は避けてください。5℃以下での作業が避けられない場合は弊社にお問合せください。

Because of slower evaporation of solvent, avoid jointing in as low as 5°C. If the jointing can not avoid, please contact us.



配管には応力低減や配管移動防止のためが発生しないように、適切な支持やスラスト防護を行ってください。
Proper pipe support or thrust block must be provide to prevent movement of pipe and to reduce excessive stress.



屋外露出配管では、紫外線による管の劣化を軽減するために配管塗装または、保護カバーの設置などの対策をしてください。なお配管塗装について、油性塗料による塗装は一部成分により合成樹脂の耐衝撃性などの強度物性を大きく低下させる場合があります。塗料は水性塗料をご使用ください。

For outdoor exposed pipes, take measures such as painting the pipes or installing a protective cover to reduce the deterioration of the pipes due to ultraviolet rays. Regarding painting of the pipes, painting with oil-based paint may significantly reduce the physical properties of plastic pipes, such as impact resistance, depending on some components. Please use water-based paint.



配管テストには必ず水圧にて行ってください。管内に空気に残らないよう排気してから加圧してください。エア等ガスで圧力テストを絶対にしないでください。

The piping system must be tested with water pressure. Apply pressure after releasing air in piping. do not use air or other gases for pressure testing.



接続部の漏れを確認する場合、市販の漏れ検知液を使用しないでください。検知液が管材に亀裂などの障害を及ぼす恐れがあります。When checking leakage in the joint, do not use any of the leakage detecting agents available on market. They might cause any damage as cracks on pipes, fittings and valves.

積水化学工業株式会社 環境・ライフラインカンパニー

プラント資材ホームページ <https://eslon-plant.jp/> E-mail: eslon_plant@sekisui.com

東北支店

設備システム営業所 〒 980-6010 宮城県仙台市青葉区中央4-6-1 (SS30)
☎ 022(217)0608

東日本支店 建築営業部

東京設備システム営業所 〒 105-8566 東京都港区虎ノ門2-10-4 (オークラプレステージタワー)
☎ 03(6748)6512

関東設備システム営業所 〒 330-0854 埼玉県さいたま市大宮区桜木町4-333-13 (大同生命さいたま大宮ビル)
☎ 048(646)0160

横浜営業所 〒 220-0004 神奈川県横浜市西区北幸2-8-4 (横浜西口KNビル)
☎ 045(311)9115

東関東営業所 〒 260-0028 千葉県千葉市中央区新町24-9 (ウエストビル)
☎ 043(204)5070

甲信営業所 〒 390-0814 長野県松本市本庄1-3-10 (大同生命松本ビル)
☎ 0263(38)1220

静岡営業所 〒 422-8067 静岡県静岡市駿河区南町14-25 (エスパティオ)
☎ 054(333)9810

中部支店

設備システム営業所 〒 450-6642 愛知県名古屋市中村区名駅1-1-3 (JRゲートタワー)
☎ 052(307)6806

西日本支店 建築営業部

近畿設備システム営業所 〒 530-8565 大阪府大阪市北区西天満2-4-4 (堂島関電ビル)
☎ 06(6365)4506

中国設備システム営業所 〒 730-0017 広島県広島市中区鉄砲町7-18 (東芝フコク生命ビル)
☎ 082(224)6251

北陸営業所 〒 920-0031 石川県金沢市広岡3-1-1 (金沢パークビル)
☎ 076(231)4245

京滋営業所 〒 601-8105 京都府京都市南区上鳥羽上調子町2-2 (京都研究所内)
☎ 075(662)3418

四国営業所 〒 760-0023 香川県高松市寿町1-2-5 (井門高松ビル)
☎ 087(821)2113

九州支店

設備システム営業所 〒 812-0033 福岡県福岡市博多区大博町1-2
☎ 092(271)1314

沖縄営業所 〒 900-0032 沖縄県那覇市松山1-1-19 (JPR那覇ビル)
☎ 098(943)2780

積水化学北海道(株) 営業本部

土木営業部 〒 001-0014 北海道札幌市北区北14条西4-2-1 (ハーモネートビル)
☎ 011(737)6330

お客様相談室 ☎ 03(6748)6480

●お問い合わせは上記各営業所へ

SEKISUI CHEMICAL CO.,LTD.

Industrial Piping Systems Division

2-10-4 Toranomon Minatoku, Tokyo, 105-8566 Japan
TEL +81-3-6748-6489 FAX +81-3-6748-6553
<https://eslon-plant.jp/web-en/> E-mail: eslon_plant@sekisui.com

SEKISUI INDUSTRIAL PIPING CO., LTD.

No.18, Jing 1st Rd., Chung Kang Export Processing Zone, Wuqi Dist., Taichung City 43541, Taiwan, R.O.C.
TEL +886-4-2657-3688 FAX +886-4-2657-9638

SEKISUI (SHANGHAI) INTERNATIONAL TRADING CO., LTD.

Room 706, Metro Tower, No.30, Tianyaoqiao Road Shanghai. 200030, China
TEL +86-21-6482-0638 FAX +86-21-6482-0639

SEKISUI SINGAPORE PTE, LTD.

7500A Beach Road #12-304/307 The Plaza 199591, Singapore
TEL +65-629-637-88 FAX +65-629-677-23

SEKISUI CHEMICAL GmbH

Roßstraße 92, 40476 Düsseldorf, Germany
TEL +49-211-36977-0 FAX +49-211-36977-31

SEKISUI VIETNAM CO., LTD.

Room1414, CornerStone Building, 16Phan Chu Trinh St, Hoan Kiem District, Hanoi, Vietnam
TEL +84-4-3939-2677 FAX +84-4-3939-2678

エスロンタイムス
プラント資材(生産設備)サイト

エスロンプラントでQ検索

<https://eslon-plant.jp>



二次元コードで
アクセスはコチラ!

*印刷のため製品の色調は実物とは異なる場合があります。
*記載事項は予告なく変更する場合があります。

不許転載

2005年 6月 全面改訂
2023年 6月 改訂9版-0刷

エスロンクリーンパイプシステム
カタログ

積水化学工業株式会社
プラントシステム事業部

ツールコード

No. 06265

2023. 7. 0TH TX